

**BID DOCUMENTS
FOR
2021 WATER SERVICE LINE REPLACEMENT PROJECT**



**CITY OF OWOSSO
301 W. MAIN STREET
OWOSSO, MICHIGAN 48867**

April 26, 2021

**NOTICE TO BIDDERS
2021 WATER SERVICE LINE REPLACEMENT PROJECT
FOR THE CITY OF OWOSSO, MICHIGAN**

Sealed proposals will be received by the city of Owosso for the **2021 WATER SERVICE LINE REPLACEMENT PROJECT** bid and should be addressed to:

Bid Coordinator
City of Owosso
301 W. Main Street
Owosso, Michigan 48867

Major items include: water service line replacements, pavement removal, HMA patching, concrete sidewalks, and turf establishment.

Bids will be accepted until **3:00 p.m. TUESDAY, MAY 25, 2021** for the **2021 WATER SERVICE LINE REPLACEMENT PROJECT** at which time bids will be publicly opened and read aloud. This bid will be considered "All or None".

"All or None" means that bidders are required to submit pricing for all items requested. Any proposal received that does not meet this requirement will be disqualified. If said bid is not listed as "All or None" the City reserves the right to split said bid to our best benefit.

All bids must be in writing and must contain an original signature by an authorized officer of the firm. Electronic bids (i.e., telephonic, fax, email, etc.) are **NOT** acceptable.

All bids must be accompanied by a Bid Bond for a sum of not less than 5% of the total bid and shall be made payable to the city of Owosso. This amount shall be forfeited in the case of failure on the part of the successful bidder to sign a contract and furnish satisfactory bonds as required within ten (10) consecutive calendar days after the acceptance of the bid by the city of Owosso.

The bidder agrees that if the city accepts their proposal, the bidder will, within 10 consecutive calendar days after receiving notice of this acceptance, enter into a contract to furnish all labor, equipment and tools necessary to execute the work at the unit prices named in the bid proposal and will furnish the surety for performance, for one hundred percent (100%) of this bid, which shall be accepted and approved by the city.

All bids shall clearly contain on the outside of the **sealed** envelope in which they are submitted:

2021 WATER SERVICE LINE REPLACEMENT PROJECT

Hard copies of the proposal, contract forms and specifications are on file and may be obtained for a fee in accordance with the city's FOIA Policy at the office of the Bid Coordinator, City Hall, 301 West Main Street, Owosso, Michigan 48867. Bid documents are available at no charge on our website at www.ci.owosso.mi.us or on the MITN website at www.mitn.info.

The city reserves the right to accept any proposal; or to reject any proposal; to waive irregularities in a proposal; or to negotiate if it appears to be in the best interest of the city of Owosso.

No work can begin before June 21, 2021 and all work is to be completed by August 6, 2021. Additional water service lines replacements may be added, at the contract unit prices, if additional repairs are needed.

INQUIRIES/ADDENDUMS

Addendums will be available on the city's website at www.ci.owosso.mi.us and on the MITN website at www.mitn.info.

All inquiries regarding this bid request must be received at least five (5) calendar days prior to the submission and shall be received in, and responded to, in writing, or via FAX at 989-723-8854 or by e-mail to Clayton Wehner at clayton.wehner@ci.owosso.mi.us. Call 989-725-0551 to arrange to field inspection.

INSTRUCTIONS TO BIDDERS

1. Each proposal must be signed by the bidder with his usual signature. Bids by partnerships should be signed with the partnership name by one of the members of the partnership or by an authorized representative, followed by the signature and title of the person signing. Proposals by corporations must be signed with the name of the corporation, followed by the signature and designation of the president, vice-president or person authorized to bind it in the matter. **Any paperwork not filled out properly or signed will cause the bid to be considered non-responsive and shall be rejected by the city.**
2. Proposals, to receive consideration, must be received prior to the specified time of opening and reading as designated in the invitation.
3. Bidders are requested to use the proposal form furnished by the city when submitting their proposals. Envelopes must be **sealed** when submitted and clearly marked on the outside indicating the name of the bid.
4. Proposals having and erasures or corrections thereon may be rejected unless explained or noted over the signature of the bidder.
5. References in the specifications or description of materials, supplies, equipment, or services to a particular trade name, manufacturer's catalog, or model number are made for descriptive purposes to guide the bidder in interpreting the type of materials or supplies, equipment, or nature of the work desired. They should not be construed as excluding proposals on equivalent types of materials, supplies, and equipment or for performing the work in a manner other than specified. However, the bidders' attention is called to General Condition seven (7).
6. Proposals should be mailed or delivered to: Bid Coordinator's Office, City Hall, 301 W. Main Street, Owosso, MI 48867.
7. Special conditions included in this inquiry shall take precedence over any conditions listed under General Conditions or Instructions to Bidders.
8. Insurance coverage – The winning bidder, prior to execution of the contract, shall file with the city copies of completed certificates of insurance naming the city of Owosso as an additional insured party, as evidence that the contractor carries adequate insurance satisfactory to the city.
9. The city of Owosso has a local preference policy for the purchase of goods and services. The policy in part states: *A business located within the city limits and paying real or personal property taxes to the city of Owosso will be granted a six percent (6%) bid advantage or \$2,500, whichever is less, over a business located outside Shiawassee County. A business located outside the city limits but within Shiawassee County and paying property taxes to the county will be granted a three percent (3%) bid advantage or \$2,500, whichever is less, over a business located outside Shiawassee County. The preference also applies to subcontractors performing twenty-five percent (25%) or more of the work of a general contract.*
10. **The following items must be included with the bid response:**
 - a. **Vendor Proposal**
 - b. **Local Preference Affidavit**
 - c. **W-9 Request for Taxpayer ID No. and Certification**
 - d. **Signature Page & Legal Status/Acknowledgement of Addendum(s)**
 - e. **Insurance Endorsement**

BID Proposal

2021 Water Service Line Replacment Project

TO: THE CITY OF OWOSSO (HEREINAFTER CALLED THE "CITY")

Bidder must provide pricing for each item listed. If additional pricing elements are being offered by the bidder, they are to be listed under "other services/items offered."

The undersigned, having examined the bid proposal forms and specifications, does hereby offer to 2021 WATER SERVICE LINE REPLACEMENT PROJECT listed below at the following prices to wit:

Item	Description	Approx. Quantity	Unit	Unit Price	Total Price
1	Water Service, Case 1, 1 inch, Curb Stop to Water Meter	190	FT		
2	Water Service, Case 2, 1 inch, Main to Curb Stop	350	FT		
3	Water Service, Case 3, 1 inch, Main to Water Meter	230	FT		
4	Failed Attempt – Cable Method	8	EA		
5	Failed Attempt – Boring Method	8	EA		
6	Water Meter Pit, Rem	8	EA		
7	Supply & Install Meter Pit, Complete	8	EA		
8	Sidewalk, Rem	70	Syd		
9	HMA, Rem	210	Syd		
10	Curb and Gutter, Rem	100	Ft		
11	Sidewalk, Conc, 4 inch, Modified	475	Sft		

Item	Description	Approx. Quantity	Unit	Unit Price	Total Price
12	Sidewalk, Conc, 6 inch, Modified	155	Sft		
13	Curb and Gutter, Conc, Det F4	100	Ft		
14	Driveway, Nonreinf, Conc, 6 inch	20	Syd		
15	HMA, Repair	95	Ton		
16	Subgrade Undercutting, Type II, Modified	50	Cyd		
17	Water Main Tap	8	Ea		

Bidder's Initial _____

BID TOTAL (ITEMS 1-17):

_____ (use words)

\$ _____ (use figures)

VARIANCE FROM SPECIFICATIONS: If the bidder is unable to comply with the specifications as outlined, the bidder shall clearly note these variations from the specifications. The bidder may also propose additions to these specifications for the city to consider, but the costs associated with these additions shall be stated separately.

If the work is not complete on or before the date set for completion or any extension, the Contractor shall pay the city liquidated damages of *six hundred (\$600.00)* a calendar day until the work is satisfactorily completed. Liquidated damages for delay may be deducted from payments due the contractor or may be collected from the Contractor or the Contractor's surety.

The undersigned agrees that if the city accepts this proposal, Contractor will, within 10 consecutive calendar days after receiving notice of this acceptance, enter into a contract to furnish all labor, equipment and tools necessary to execute the work at the unit prices named in the bid proposal. Contractor will furnish the surety for performance, for 100% of this bid, which shall be accepted and approved by the city.

The undersigned agrees that if the city accepts this proposal, Contractor will start this project no sooner than June 21, 2021 and will substantially complete the entire work under this contract by August 6, 2021. This schedule may be extended for rain days or cold weather for calendar days after August 6, 2021, only as approved by the city of Owosso. **Additional water service lines replacements may be added, at the contract unit prices, if additional repairs are needed.**

On behalf of _____, I hereby submit this proposal for 2021 WATER SERVICE LINE REPLACEMENT PROJECT for your consideration. The undersigned acknowledges that this proposal is subject to the General Conditions and the General Specifications included in the contract documents. In submitting this proposal, it is understood that the right is reserved by the CITY to reject any and all proposals, and waive any irregularities in the bidding process. The CITY may award this contract based on any combination of the total bid and/or alternates.

Dated and signed at _____ State of _____

This _____ day of _____, 20____.

Bidder

Witness:

By/s/

Business Address

Signature

Printed Name

Title

Telephone Number

E-Mail Address

GENERAL CONDITIONS

1. LOCAL PREFERENCE POLICY

The city of Owosso has a local preference policy for the purchase of goods and services. The policy in part states: *A business located within the city limits and paying real or personal property taxes to the city of Owosso will be granted a 6% bid advantage or \$2,500, whichever is less, over a business located outside Shiawassee County. A business located outside the city limits but within Shiawassee County and paying property taxes to the county will be granted a 3% bid advantage or \$2,500, whichever is less, over a business located outside Shiawassee County. The preference also applies to subcontractors performing 25% or more of the work of a general contract.*

2. BID ACCEPTANCE

The city reserves the right to reject any or all proposals. Unless otherwise specified, the city reserves the right to accept any item in the proposal. In case of error in extending the total amount of the bid, the unit prices shall govern. The city objects to any additional terms stated in any documents submitted by the contractor. Performance pursuant to our Purchase Order/Equipment Agreement constitutes a course of conduct consisting of Contractor's Agreement to the terms of our Purchase Order/Equipment Agreement.

3. PAYMENT

Unless otherwise stated by the bidder, time, concerning discount offered, will be computed from date of delivery and acceptance at destination or from date correct bill or claim voucher properly certified by the contractor is received. When so stated herein, partial payments, based on a certified approved estimate by the city of materials, supplies or equipment delivered or work done, may be made upon presentation of a properly-executed claim voucher. The final payment will be made by the city when materials, supplies, equipment or the work done have been fully delivered or completed to the full satisfaction of the city.

4. BID DEFAULT

In case of default by the bidder or contractor, the city of Owosso may procure the articles or services from other sources and hold the bidder or contractor responsible for any excess cost occasioned thereby.

5. UNIT PRICES

Prices should be stated in units of quantity specified.

6. QUOTED PRICES

Unless otherwise stated by the bidder, prices quoted will be considered as being based on delivery to a designated destination and to include all charges for packing, crating, containers, shipping, etc., and being in strict accordance with specifications and standards as shown.

7. SUBSTITUTIONS

Wherever a reference is made in the specifications or description of the materials, supplies, equipment, or services required, to a particular trade name, manufacturer's catalog, or model number, the bidder, if awarded a contract or order, will be required to furnish the particular item referred to in strict accordance with the specifications or description unless a departure or substitution is clearly noted and described in the proposal.

8. HOLD CITY HARMLESS

The bidder, if awarded an order or contract, agrees to protect, defend, and save the city harmless against any demand for payment for the use of any patented material, process, article, or device that may enter into the manufacture, construction, or form a part of the work covered by either order or contract. Bidder further agrees to indemnify and save the city harmless from suits or action of every nature and description

brought against it, for or on account of any injuries or damages received or sustained by any party or parties, by or from any of the acts of the contractor, his employees, subcontractors, or agents.

9. COMPETITIVE BIDDING STATUTES

The laws of the state of Michigan, the charter and ordinances of the city of Owosso, as far as they apply to the laws of competitive bidding, contracts and purchases, are made a part hereof.

10. SAMPLES

Samples, when requested, must be furnished free of expense to the city and, if not destroyed, will upon request be returned at the bidder' expense.

11. BONDS

A bid bond may be required, payable to the City of Owosso. If so required in the bid documents, a performance bond and labor and material bond in the amounts stated in the bid documents, shall be on file with the city before work commences. The city will determine the amount and sufficiency of the sureties.

12. PROPOSAL GUARANTEE

All checks or bid bonds, except those of the three lowest bidders, will be returned when the bids have been opened and tabulated. The certified checks or bid bonds of the three lowest bidders will be held until the contract documents have been signed, after which remaining certified checks or bid bonds will be returned to the respective bidders.

13. BIDDERS

The city may demand that the contractor file a sworn experience and financial statement setting forth the financial resources, adequacy of plant and equipment, organization, experience and other pertinent and material facts as may be desirable.

14. INSURANCE AND HOLD HARMLESS

To the fullest extent permitted by law the Contractor agrees to defend, pay on behalf of, indemnify, and hold harmless the City of Owosso, its elected and appointed officials, employees, agents and volunteers, and others working on behalf of the City of Owosso against any and all claims, demands, suits, or loss, including all costs connected therewith, and for any damages which may be asserted, claimed, or recovered against or from the City of Owosso, by reason of personal injury, including bodily injury or death and/or property damage, including loss of use thereof, for all actions of the Contractor.

Contractor shall not commence work under this contract until they have obtained the insurance required under this paragraph, and shall keep such insurance in force during the entire life of this contract. All coverage shall be with insurance companies licensed and admitted to do business in the State of Michigan and acceptable to the City of Owosso. The requirements below should not be interpreted to limit the liability of Contractor. All deductibles and SIR's are the responsibility of Contractor. Contractor shall procure and maintain the following insurance coverage:

- a. Worker's Compensation Insurance including Employers' Liability Coverage, in accordance with all applicable statutes of the State of Michigan.
- b. Commercial General Liability Insurance on an "Occurrence Basis" with limits of liability not less than \$1,000,000 per occurrence and aggregate. Coverage shall include the following extensions: (A) Contractual Liability; (B) Products and Completed Operations; (C) Independent Contractors

Coverage; (D) Broad Form General Liability Extensions or equivalent, if not already included. (E) Explosion, Collapse, and Underground (XCU) coverage, if applicable. Limits may be obtained by the use of primary and excess/umbrella liability policies.

- c. Automobile Liability including Michigan No-Fault Coverages, with limits of liability not less than \$1,000,000 per occurrence, combined single limit for Bodily Injury, and Property Damage. Coverage shall include all owned vehicles, all non-owned vehicles, and all hired vehicles.
- d. Owners' and Contractor Protective Liability: The Contractor shall procure and maintain during the life of this contract, a separate Owners' and Contractor's Protective Liability Policy with limits of liability not less than \$1,000,000 per occurrence and aggregate for Personal Injury, Bodily Injury, and Property Damage. The City of Owosso shall be the "Named Insured" on said coverage.
- e. Additional Insured: Commercial General Liability and Automobile Liability as described above shall include an endorsement stating the City of Owosso shall be listed as additional insured. It is understood and agreed by naming the City of Owosso as additional insured, coverage afforded is considered to be primary and any other insurance the City of Owosso may have in effect shall be considered secondary and/or excess.
- f. Cancellation Notice: All policies, as described above, shall include an endorsement stating that it is understood and agreed Thirty (30) days, Ten (10) days for non-payment of premium, Advance Written Notice of Cancellation, shall be sent to: **(The City of Owosso, Debbie Hebert, Insurance Coordinator, 301 W. Main Street, Owosso, MI 48867).**
- g. Proof of Insurance Coverage: Contractor shall provide the City of Owosso at the time that the contracts are returned by him/her for execution, a Certificate of Insurance as well as the required endorsements. In lieu of required endorsements, if applicable, a copy of the policy sections where coverage is provided for additional insured and cancellation notice would be acceptable.

If any of the above coverages expire during the term of this contract, the Contractor shall deliver renewal certificates and endorsements to the City of Owosso at least ten (10) days prior to the expiration date.

15. PROTECTION OF LAND MONUMENTS AND PROPERTY STAKES

Land monuments or stakes marking property corners shall not be moved or otherwise disturbed except as directed by the city. If any land monuments or lot stakes are moved or disturbed by the contractor, the cost of replacing each land monument or lot stake so moved or disturbed shall be deducted from any money due the contractor, as payment to the city for the cost of replacing said land monument or lot stakes.

16. CONTRACTOR'S RESPONSIBILITY FOR WORK

The contractor shall be responsible for any damages that the work may sustain before its acceptance, and shall rebuild, repair, restore and make good, at its own expense, all injuries and damages to any portion of the work by the action of the elements or from any cause whatsoever before its acceptance. Neither the final payment nor any provision in the contract documents shall relieve the contractor of the responsibility for negligence or faulty materials or workmanship within the extent and period provided by law, and, upon written notice, the contractor shall remove any defects due therefrom and pay for any damaged due to other work resulting therefrom, which shall appear within one year after the date of completion and acceptance.

17. PAYMENT

At monthly intervals commencing after construction has been started, the city will make partial payment to the contractor based on a duly-certified estimate prepared by the city of the work done by the contractor during the preceding four-week period. Each estimate will be submitted to the city council for approval on either the first or third Monday of each month. The city will retain ten percent (10%) of the amount of each such estimate until final completion and acceptance of all work covered by this contract. Before the contractor shall demand final estimates or payment, contractor will furnish to the city, supported by sworn statements, satisfactory evidence that all persons that have supplied labor, materials, or equipment for the work embraced under this contract have been fully paid for the same; and that, in case such evidence be not furnished as aforesaid, such sums as the city may deem necessary to meet the lawful claims of such persons may be retained by the city from any monies that may be due or become due to the contractor under this contract until such liabilities shall be fully discharged and the evidence thereof be furnished to the city.

18. CITY'S RIGHT TO WITHHOLD CERTAIN AMOUNTS AND MAKE APPLICATION THEREOF

Besides the payment to be retained by the city under the preceding provisions of these general conditions, the city may withhold a sufficient amount of any payment otherwise due to the contractor to cover a) payments earned or due for just claims for furnish labor or materials on the project under this contract, b) for defective work not remedied and c) for failure of the contractor to make proper payments to subcontractors. The city shall disburse and shall have the right to act as agent for the contractor in disbursing such funds as have been previously withheld pursuant to this paragraph to the party or parties who are entitled to payment from it. The city will pay to the contractor a proper accounting of all such funds disbursed for the contractor.

19. OWNER'S RIGHT TO DO WORK

If the contractor should neglect to prosecute the work properly or fail to perform any provisions of this contract, the city, after three (3) days' written notice to the contractor and contractor's surety, may without prejudice to any other remedy he may have, make good such deficiencies and may deduct the cost of it from the payment due the contractor.

20. DEFINITION OF NOTICE

Where in any of the contract documents there is any provision in respect to the giving of notice, such notice shall be deemed given to the owner, when written notice is delivered to the city manager, or placed in the United States mail addressed to the city clerk; as to the contractor, when a written notice shall be delivered to contractor's representative at the project site or by mailing such written notice in the United States mail addressed to the contractor at the place stated in the bid proposal as the business address; as to the surety on the performance bond, when a written notice is placed in the United States mail addressed to the surety at the surety's home office or to its agent or agents who executed such performance bond on behalf of the surety.

21. SUBCONTRACTS

The contractor shall not subcontract any work in the execution of this contract without the written consent of the city. The contractor shall be responsible for the acts or omissions of any subcontractor and of anyone employed directly or indirectly by such subcontractor.

22. ASSIGNMENT OF CONTRACT

The contractor shall not assign this contract or any part hereof without the written consent of the city. No assignment shall be valid unless it shall contain a provision that any funds to be paid to the assignee under this agreement are subject to a prior lien for services rendered or materials or supplies for the performance of the work specified in the contract in favor of all persons, firms, or corporations rendering such services or supplying such materials.

23. MAINTAINING TRAFFIC

The contractor shall provide flares, signs, barricades, traffic regulators, etc., to conform to the current *Michigan Manual of Uniform Traffic Control Devices* or as directed by the city. The contractor shall not close any road or street without the permission of the city. If any street or road is to be closed by the contractor, it shall be the responsibility of the contractor to notify the Owosso fire department when the street will be closed and again when the street is open to traffic. Traffic control devices for any detours deemed necessary by the city shall be provided by the contractor. Cost of maintaining shall be incidental to the cost of the project unless otherwise provided.

24. ORDER OF COMPLETION

The contractor shall submit, whenever requested by the city, a schedule of the work showing completion dates. The city may request that certain portions of the work be done before other portions. If so requested, the contractor shall arrange to schedule to meet the request by the owner.

25. USE OF COMPLETED PORTIONS

The city shall have the right to take possession and use any completed or partially completed portions of the work; but such taking possession and use shall not be deemed acceptance. Pending final completion and acceptance of the work, all necessary repairs and adjustments on any section of the work due to defective material, workmanship, natural causes, or other operations of the contractor, other than normal wear and tear, shall be done by and at the expense of the contractor.

26. WATER SUPPLY

The contractor shall secure an adequate water supply for use in construction and for drinking water for his employees. If the city's water is used on the work, the contractor shall make the necessary application and shall pay all costs involved. Connections, piping and fittings for conveying water shall be furnished and maintained by the contractor. Contractor shall pay for water according to the city's established rates.

27. CLEANUP

The contractor shall keep the project free from waste materials or rubbish caused by its employees or work. This includes as a minimum excess excavation or backfill material, broken or rejected materials, empty containers or general debris. The owner may require complete cleanup of certain areas as construction is completed.

28. SUPERVISION

The contractor shall have a superintendent on the job site to coordinate and expedite the various construction activities for the duration of this contract.

29. EQUAL EMPLOYMENT OPPORTUNITY AND OTHER CLAUSES

The contractor shall agree not to discriminate against any employee or applicant for employment because of age, race, religion, color, handicap, sex, physical condition, developmental disability as defined by Michigan Compiled Statutes, or national origin. This provision shall include but not be limited to the following: employment, upgrading, demotion or transfer, recruitment or recruitment advertising, layoff or termination, rate of pay or other forms of compensation, and selection for training including apprenticeship. The contractor further agrees to take affirmative action to ensure equal employment opportunities for persons with disabilities. The contractor agrees to post in conspicuous places, available to employees and applicants for employment, notices setting forth the provision of the non-discrimination clause.

LOCAL PREFERENCE POLICY

The following affidavit should be completed if a bidder is located within Shiawassee County or intends to sub-contract more than twenty-five percent (25%) to a Shiawassee County based business: The city of Owosso has a local preference policy for the purchase of goods and services as recorded in the city ordinance in section 2-348. "Lowest qualified bidder" defined.

1. The term "lowest qualified bidder," as used in this division, shall mean the lowest bidder having qualifications to perform the work which are satisfactory to the council. The lowest bidder shall be determined based on an adjusted bid tabulation which shall be prepared in the following manner: To the bid of any bidder which is neither a city-based business nor a county-based business shall be added an amount equal to six (6) percent of the bid or two thousand five hundred dollars (\$2,500.00), whichever is less.
2. To the bid of any bidder which is a county-based business shall be added an amount equal to three (3) percent of the bid or two thousand five hundred dollars (\$2,500.00), whichever is less; provided, however, that if no bid is received from a city-based business, no additional amount shall be added to the bid of a county-based business.
3. "Owosso-based business" shall be interpreted to mean a business registered with the county clerk or a corporation registered with the state having a business address within the city limits which pays real and/or personal property taxes levied by the city.

The term "county-based business" shall be interpreted to mean a business other than a city-based business registered with the county clerk or a corporation registered with the state having a business address within the county which pays real and/or personal property taxes levied by the county.

4. If twenty-five (25) percent or more of a contract for construction or other services is to be subcontracted by a city-based business bidder to a non-city-based business or businesses, or by a county-based business bidder to a non-county-based business or businesses, the adjusted bid shall be calculated by applying the provisions of this section separately to each portion of the contract based on the status of the contractor or subcontractor performing that portion of the contract as a city-based or county-based business.

AFFIDAVIT

In accordance with Section 2-348 of the Owosso city code, the bid from a business located in Shiawassee County shall be adjusted to reflect a preference. In order for the city to calculate the adjustment, the bidder hereby deposes and states that their business address is registered, and is currently paying real and/or personal property taxes in Shiawassee County at the following address:

Registered business address

The affiant further deposes and states that a sub-contract with a business registered, and paying real and/or personal property taxes in Shiawassee County will be executed for a percentage equal to or greater than twenty-five percent (25%) as stated below:

Business name and address of sub-contractor

Percentage of contract

Authorized signature

Date

Title

Company name

SIGNATURE PAGE AND LEGAL STATUS

The undersigned certifies that he is an official legally authorized to bind his firm and to enter into a contract should the city accept this proposal.

Bid proposal by _____
(Name of Firm)

Legal status of bidder. Please check the appropriate box and **USE CORRECT LEGAL NAME.**

A. Corporation ____ ; State of Incorporation _____

B. Partnership ____ ; List of names _____

C. DBA ____ ; State full name _____ DBA

D. Other ____ ; Explain _____

Signature of Bidder _____ Title _____
(Authorized Signature)

Printed name _____

Signature of Bidder _____ Title _____
(Authorized Signature)

Printed name _____

Address _____ City _____ Zip _____

Telephone () _____

Signed this _____ day of _____ 20____.

Bidder acknowledges receipt of the following Addenda:

ADDENDUM NO.	BIDDER'S INITIALS
_____	_____
_____	_____
_____	_____

W-9 INFORMATION FOR LEGAL STATUS

Sole proprietor. Enter your individual name as shown on your income tax return on the “Name” line. You may enter your business, trade, or “doing business as (DBA)” name on the “Business name/disregarded entity name” line.

Partnership, C Corporation, or S Corporation. Enter the entity's name on the “Name” line and any business, trade, or “doing business as (DBA) name” on the “Business name/disregarded entity name” line.

Disregarded entity. Enter the owner's name on the “Name” line. The name of the entity entered on the “Name” line should never be a disregarded entity. The name on the “Name” line must be the name shown on the income tax return on which the income will be reported. For example, if a foreign LLC that is treated as a disregarded entity for U.S. federal tax purposes has a domestic owner, the domestic owner's name is required to be provided on the “Name” line. If the direct owner of the entity is also a disregarded entity, enter the first owner that is not disregarded for federal tax purposes. Enter the disregarded entity's name on the “Business name/disregarded entity name” line. If the owner of the disregarded entity is a foreign person, you must complete an appropriate Form W-8.

Note. Check the appropriate box for the federal tax classification of the person whose name is entered on the “Name” line (Individual/sole proprietor, Partnership, C Corporation, S Corporation, Trust/estate).

Limited Liability Company (LLC). If the person identified on the “Name” line is an LLC, check the “Limited liability company” box only and enter the appropriate code for the tax classification in the space provided. If you are an LLC that is treated as a partnership for federal tax purposes, enter “P” for partnership. If you are an LLC that has filed a Form 8832 or a Form 2553 to be taxed as a corporation, enter “C” for C corporation or “S” for S corporation. If you are an LLC that is disregarded as an entity separate from its owner under Regulation section 301.7701-3 (except for employment and excise tax), do not check the LLC box unless the owner of the LLC (required to be identified on the “Name” line) is another LLC that is not disregarded for federal tax purposes. If the LLC is disregarded as an entity separate from its owner, enter the appropriate tax classification of the owner identified on the “Name” line.

Other entities. Enter your business name as shown on required federal tax documents on the “Name” line. This name should match the name shown on the charter or other legal document creating the entity. You may enter any business, trade, or DBA name on the “Business name/disregarded entity name” line.

Please see attached W-9 Request for Taxpayer Identification Number and Certification form for a detailed explanation on filling out the W-9 form.

Request for Taxpayer Identification Number and Certification

**Give Form to the
 requester. Do not
 send to the IRS.**

▶ Go to www.irs.gov/FormW9 for instructions and the latest information.

Print or type. See Specific Instructions on page 3.	1 Name (as shown on your income tax return). Name is required on this line; do not leave this line blank.	
	2 Business name/disregarded entity name, if different from above	
	3 Check appropriate box for federal tax classification of the person whose name is entered on line 1. Check only one of the following seven boxes.	4 Exemptions (codes apply only to certain entities, not individuals; see instructions on page 3):
	<input type="checkbox"/> Individual/sole proprietor or single-member LLC <input type="checkbox"/> C Corporation <input type="checkbox"/> S Corporation <input type="checkbox"/> Partnership <input type="checkbox"/> Trust/estate	Exempt payee code (if any) _____
	<input type="checkbox"/> Limited liability company. Enter the tax classification (C=C corporation, S=S corporation, P=Partnership) ▶ _____ Note: Check the appropriate box in the line above for the tax classification of the single-member owner. Do not check LLC if the LLC is classified as a single-member LLC that is disregarded from the owner unless the owner of the LLC is another LLC that is not disregarded from the owner for U.S. federal tax purposes. Otherwise, a single-member LLC that is disregarded from the owner should check the appropriate box for the tax classification of its owner.	Exemption from FATCA reporting code (if any) _____
	<input type="checkbox"/> Other (see instructions) ▶ _____	<small>(Applies to accounts maintained outside the U.S.)</small>
	5 Address (number, street, and apt. or suite no.) See instructions.	Requester's name and address (optional)
6 City, state, and ZIP code		
7 List account number(s) here (optional)		

Part I Taxpayer Identification Number (TIN)

Enter your TIN in the appropriate box. The TIN provided must match the name given on line 1 to avoid backup withholding. For individuals, this is generally your social security number (SSN). However, for a resident alien, sole proprietor, or disregarded entity, see the instructions for Part I, later. For other entities, it is your employer identification number (EIN). If you do not have a number, see *How to get a TIN*, later.

Note: If the account is in more than one name, see the instructions for line 1. Also see *What Name and Number To Give the Requester* for guidelines on whose number to enter.

Social security number									
or									
Employer identification number									

Part II Certification

Under penalties of perjury, I certify that:

1. The number shown on this form is my correct taxpayer identification number (or I am waiting for a number to be issued to me); and
2. I am not subject to backup withholding because: (a) I am exempt from backup withholding, or (b) I have not been notified by the Internal Revenue Service (IRS) that I am subject to backup withholding as a result of a failure to report all interest or dividends, or (c) the IRS has notified me that I am no longer subject to backup withholding; and
3. I am a U.S. citizen or other U.S. person (defined below); and
4. The FATCA code(s) entered on this form (if any) indicating that I am exempt from FATCA reporting is correct.

Certification instructions. You must cross out item 2 above if you have been notified by the IRS that you are currently subject to backup withholding because you have failed to report all interest and dividends on your tax return. For real estate transactions, item 2 does not apply. For mortgage interest paid, acquisition or abandonment of secured property, cancellation of debt, contributions to an individual retirement arrangement (IRA), and generally, payments other than interest and dividends, you are not required to sign the certification, but you must provide your correct TIN. See the instructions for Part II, later.

Sign Here	Signature of U.S. person ▶	Date ▶
------------------	----------------------------	--------

General Instructions

Section references are to the Internal Revenue Code unless otherwise noted.

Future developments. For the latest information about developments related to Form W-9 and its instructions, such as legislation enacted after they were published, go to www.irs.gov/FormW9.

Purpose of Form

An individual or entity (Form W-9 requester) who is required to file an information return with the IRS must obtain your correct taxpayer identification number (TIN) which may be your social security number (SSN), individual taxpayer identification number (ITIN), adoption taxpayer identification number (ATIN), or employer identification number (EIN), to report on an information return the amount paid to you, or other amount reportable on an information return. Examples of information returns include, but are not limited to, the following.

- Form 1099-INT (interest earned or paid)

- Form 1099-DIV (dividends, including those from stocks or mutual funds)
- Form 1099-MISC (various types of income, prizes, awards, or gross proceeds)
- Form 1099-B (stock or mutual fund sales and certain other transactions by brokers)
- Form 1099-S (proceeds from real estate transactions)
- Form 1099-K (merchant card and third party network transactions)
- Form 1098 (home mortgage interest), 1098-E (student loan interest), 1098-T (tuition)
- Form 1099-C (canceled debt)
- Form 1099-A (acquisition or abandonment of secured property)

Use Form W-9 only if you are a U.S. person (including a resident alien), to provide your correct TIN.

If you do not return Form W-9 to the requester with a TIN, you might be subject to backup withholding. See What is backup withholding, later.

By signing the filled-out form, you:

1. Certify that the TIN you are giving is correct (or you are waiting for a number to be issued),
2. Certify that you are not subject to backup withholding, or
3. Claim exemption from backup withholding if you are a U.S. exempt payee. If applicable, you are also certifying that as a U.S. person, your allocable share of any partnership income from a U.S. trade or business is not subject to the withholding tax on foreign partners' share of effectively connected income, and
4. Certify that FATCA code(s) entered on this form (if any) indicating that you are exempt from the FATCA reporting, is correct. See *What is FATCA reporting*, later, for further information.

Note: If you are a U.S. person and a requester gives you a form other than Form W-9 to request your TIN, you must use the requester's form if it is substantially similar to this Form W-9.

Definition of a U.S. person. For federal tax purposes, you are considered a U.S. person if you are:

- An individual who is a U.S. citizen or U.S. resident alien;
- A partnership, corporation, company, or association created or organized in the United States or under the laws of the United States;
- An estate (other than a foreign estate); or
- A domestic trust (as defined in Regulations section 301.7701-7).

Special rules for partnerships. Partnerships that conduct a trade or business in the United States are generally required to pay a withholding tax under section 1446 on any foreign partners' share of effectively connected taxable income from such business. Further, in certain cases where a Form W-9 has not been received, the rules under section 1446 require a partnership to presume that a partner is a foreign person, and pay the section 1446 withholding tax. Therefore, if you are a U.S. person that is a partner in a partnership conducting a trade or business in the United States, provide Form W-9 to the partnership to establish your U.S. status and avoid section 1446 withholding on your share of partnership income.

In the cases below, the following person must give Form W-9 to the partnership for purposes of establishing its U.S. status and avoiding withholding on its allocable share of net income from the partnership conducting a trade or business in the United States.

- In the case of a disregarded entity with a U.S. owner, the U.S. owner of the disregarded entity and not the entity;
- In the case of a grantor trust with a U.S. grantor or other U.S. owner, generally, the U.S. grantor or other U.S. owner of the grantor trust and not the trust; and
- In the case of a U.S. trust (other than a grantor trust), the U.S. trust (other than a grantor trust) and not the beneficiaries of the trust.

Foreign person. If you are a foreign person or the U.S. branch of a foreign bank that has elected to be treated as a U.S. person, do not use Form W-9. Instead, use the appropriate Form W-8 or Form 8233 (see Pub. 515, *Withholding of Tax on Nonresident Aliens and Foreign Entities*).

Nonresident alien who becomes a resident alien. Generally, only a nonresident alien individual may use the terms of a tax treaty to reduce or eliminate U.S. tax on certain types of income. However, most tax treaties contain a provision known as a "saving clause." Exceptions specified in the saving clause may permit an exemption from tax to continue for certain types of income even after the payee has otherwise become a U.S. resident alien for tax purposes.

If you are a U.S. resident alien who is relying on an exception contained in the saving clause of a tax treaty to claim an exemption from U.S. tax on certain types of income, you must attach a statement to Form W-9 that specifies the following five items.

1. The treaty country. Generally, this must be the same treaty under which you claimed exemption from tax as a nonresident alien.
2. The treaty article addressing the income.
3. The article number (or location) in the tax treaty that contains the saving clause and its exceptions.
4. The type and amount of income that qualifies for the exemption from tax.
5. Sufficient facts to justify the exemption from tax under the terms of the treaty article.

Example. Article 20 of the U.S.-China income tax treaty allows an exemption from tax for scholarship income received by a Chinese student temporarily present in the United States. Under U.S. law, this student will become a resident alien for tax purposes if his or her stay in the United States exceeds 5 calendar years. However, paragraph 2 of the first Protocol to the U.S.-China treaty (dated April 30, 1984) allows the provisions of Article 20 to continue to apply even after the Chinese student becomes a resident alien of the United States. A Chinese student who qualifies for this exception (under paragraph 2 of the first protocol) and is relying on this exception to claim an exemption from tax on his or her scholarship or fellowship income would attach to Form W-9 a statement that includes the information described above to support that exemption.

If you are a nonresident alien or a foreign entity, give the requester the appropriate completed Form W-8 or Form 8233.

Backup Withholding

What is backup withholding? Persons making certain payments to you must under certain conditions withhold and pay to the IRS 24% of such payments. This is called "backup withholding." Payments that may be subject to backup withholding include interest, tax-exempt interest, dividends, broker and barter exchange transactions, rents, royalties, nonemployee pay, payments made in settlement of payment card and third party network transactions, and certain payments from fishing boat operators. Real estate transactions are not subject to backup withholding.

You will not be subject to backup withholding on payments you receive if you give the requester your correct TIN, make the proper certifications, and report all your taxable interest and dividends on your tax return.

Payments you receive will be subject to backup withholding if:

1. You do not furnish your TIN to the requester,
2. You do not certify your TIN when required (see the instructions for Part II for details),
3. The IRS tells the requester that you furnished an incorrect TIN,
4. The IRS tells you that you are subject to backup withholding because you did not report all your interest and dividends on your tax return (for reportable interest and dividends only), or
5. You do not certify to the requester that you are not subject to backup withholding under 4 above (for reportable interest and dividend accounts opened after 1983 only).

Certain payees and payments are exempt from backup withholding. See *Exempt payee code*, later, and the separate Instructions for the Requester of Form W-9 for more information.

Also see *Special rules for partnerships*, earlier.

What is FATCA Reporting?

The Foreign Account Tax Compliance Act (FATCA) requires a participating foreign financial institution to report all United States account holders that are specified United States persons. Certain payees are exempt from FATCA reporting. See *Exemption from FATCA reporting code*, later, and the Instructions for the Requester of Form W-9 for more information.

Updating Your Information

You must provide updated information to any person to whom you claimed to be an exempt payee if you are no longer an exempt payee and anticipate receiving reportable payments in the future from this person. For example, you may need to provide updated information if you are a C corporation that elects to be an S corporation, or if you no longer are tax exempt. In addition, you must furnish a new Form W-9 if the name or TIN changes for the account; for example, if the grantor of a grantor trust dies.

Penalties

Failure to furnish TIN. If you fail to furnish your correct TIN to a requester, you are subject to a penalty of \$50 for each such failure unless your failure is due to reasonable cause and not to willful neglect.

Civil penalty for false information with respect to withholding. If you make a false statement with no reasonable basis that results in no backup withholding, you are subject to a \$500 penalty.

Criminal penalty for falsifying information. Willfully falsifying certifications or affirmations may subject you to criminal penalties including fines and/or imprisonment.

Misuse of TINs. If the requester discloses or uses TINs in violation of federal law, the requester may be subject to civil and criminal penalties.

Specific Instructions

Line 1

You must enter one of the following on this line; **do not** leave this line blank. The name should match the name on your tax return.

If this Form W-9 is for a joint account (other than an account maintained by a foreign financial institution (FFI)), list first, and then circle, the name of the person or entity whose number you entered in Part I of Form W-9. If you are providing Form W-9 to an FFI to document a joint account, each holder of the account that is a U.S. person must provide a Form W-9.

a. **Individual.** Generally, enter the name shown on your tax return. If you have changed your last name without informing the Social Security Administration (SSA) of the name change, enter your first name, the last name as shown on your social security card, and your new last name.

Note: ITIN applicant: Enter your individual name as it was entered on your Form W-7 application, line 1a. This should also be the same as the name you entered on the Form 1040/1040A/1040EZ you filed with your application.

b. **Sole proprietor or single-member LLC.** Enter your individual name as shown on your 1040/1040A/1040EZ on line 1. You may enter your business, trade, or “doing business as” (DBA) name on line 2.

c. **Partnership, LLC that is not a single-member LLC, C corporation, or S corporation.** Enter the entity’s name as shown on the entity’s tax return on line 1 and any business, trade, or DBA name on line 2.

d. **Other entities.** Enter your name as shown on required U.S. federal tax documents on line 1. This name should match the name shown on the charter or other legal document creating the entity. You may enter any business, trade, or DBA name on line 2.

e. **Disregarded entity.** For U.S. federal tax purposes, an entity that is disregarded as an entity separate from its owner is treated as a “disregarded entity.” See Regulations section 301.7701-2(c)(2)(iii). Enter the owner’s name on line 1. The name of the entity entered on line 1 should never be a disregarded entity. The name on line 1 should be the name shown on the income tax return on which the income should be reported. For example, if a foreign LLC that is treated as a disregarded entity for U.S. federal tax purposes has a single owner that is a U.S. person, the U.S. owner’s name is required to be provided on line 1. If the direct owner of the entity is also a disregarded entity, enter the first owner that is not disregarded for federal tax purposes. Enter the disregarded entity’s name on line 2, “Business name/disregarded entity name.” If the owner of the disregarded entity is a foreign person, the owner must complete an appropriate Form W-8 instead of a Form W-9. This is the case even if the foreign person has a U.S. TIN.

Line 2

If you have a business name, trade name, DBA name, or disregarded entity name, you may enter it on line 2.

Line 3

Check the appropriate box on line 3 for the U.S. federal tax classification of the person whose name is entered on line 1. Check only one box on line 3.

IF the entity/person on line 1 is a(n) . . .	THEN check the box for . . .
• Corporation	Corporation
• Individual • Sole proprietorship, or • Single-member limited liability company (LLC) owned by an individual and disregarded for U.S. federal tax purposes.	Individual/sole proprietor or single-member LLC
• LLC treated as a partnership for U.S. federal tax purposes, • LLC that has filed Form 8832 or 2553 to be taxed as a corporation, or • LLC that is disregarded as an entity separate from its owner but the owner is another LLC that is not disregarded for U.S. federal tax purposes.	Limited liability company and enter the appropriate tax classification. (P= Partnership; C= C corporation; or S= S corporation)
• Partnership	Partnership
• Trust/estate	Trust/estate

Line 4, Exemptions

If you are exempt from backup withholding and/or FATCA reporting, enter in the appropriate space on line 4 any code(s) that may apply to you.

Exempt payee code.

- Generally, individuals (including sole proprietors) are not exempt from backup withholding.
- Except as provided below, corporations are exempt from backup withholding for certain payments, including interest and dividends.
- Corporations are not exempt from backup withholding for payments made in settlement of payment card or third party network transactions.
- Corporations are not exempt from backup withholding with respect to attorneys’ fees or gross proceeds paid to attorneys, and corporations that provide medical or health care services are not exempt with respect to payments reportable on Form 1099-MISC.

The following codes identify payees that are exempt from backup withholding. Enter the appropriate code in the space in line 4.

- 1—An organization exempt from tax under section 501(a), any IRA, or a custodial account under section 403(b)(7) if the account satisfies the requirements of section 401(f)(2)
- 2—The United States or any of its agencies or instrumentalities
- 3—A state, the District of Columbia, a U.S. commonwealth or possession, or any of their political subdivisions or instrumentalities
- 4—A foreign government or any of its political subdivisions, agencies, or instrumentalities
- 5—A corporation
- 6—A dealer in securities or commodities required to register in the United States, the District of Columbia, or a U.S. commonwealth or possession
- 7—A futures commission merchant registered with the Commodity Futures Trading Commission
- 8—A real estate investment trust
- 9—An entity registered at all times during the tax year under the Investment Company Act of 1940
- 10—A common trust fund operated by a bank under section 584(a)
- 11—A financial institution
- 12—A middleman known in the investment community as a nominee or custodian
- 13—A trust exempt from tax under section 664 or described in section 4947

The following chart shows types of payments that may be exempt from backup withholding. The chart applies to the exempt payees listed above, 1 through 13.

IF the payment is for . . .	THEN the payment is exempt for . . .
Interest and dividend payments	All exempt payees except for 7
Broker transactions	Exempt payees 1 through 4 and 6 through 11 and all C corporations. S corporations must not enter an exempt payee code because they are exempt only for sales of noncovered securities acquired prior to 2012.
Barter exchange transactions and patronage dividends	Exempt payees 1 through 4
Payments over \$600 required to be reported and direct sales over \$5,000 ¹	Generally, exempt payees 1 through 5 ²
Payments made in settlement of payment card or third party network transactions	Exempt payees 1 through 4

¹ See Form 1099-MISC, Miscellaneous Income, and its instructions.

² However, the following payments made to a corporation and reportable on Form 1099-MISC are not exempt from backup withholding: medical and health care payments, attorneys' fees, gross proceeds paid to an attorney reportable under section 6045(f), and payments for services paid by a federal executive agency.

Exemption from FATCA reporting code. The following codes identify payees that are exempt from reporting under FATCA. These codes apply to persons submitting this form for accounts maintained outside of the United States by certain foreign financial institutions. Therefore, if you are only submitting this form for an account you hold in the United States, you may leave this field blank. Consult with the person requesting this form if you are uncertain if the financial institution is subject to these requirements. A requester may indicate that a code is not required by providing you with a Form W-9 with "Not Applicable" (or any similar indication) written or printed on the line for a FATCA exemption code.

A—An organization exempt from tax under section 501(a) or any individual retirement plan as defined in section 7701(a)(37)

B—The United States or any of its agencies or instrumentalities

C—A state, the District of Columbia, a U.S. commonwealth or possession, or any of their political subdivisions or instrumentalities

D—A corporation the stock of which is regularly traded on one or more established securities markets, as described in Regulations section 1.1472-1(c)(1)(i)

E—A corporation that is a member of the same expanded affiliated group as a corporation described in Regulations section 1.1472-1(c)(1)(i)

F—A dealer in securities, commodities, or derivative financial instruments (including notional principal contracts, futures, forwards, and options) that is registered as such under the laws of the United States or any state

G—A real estate investment trust

H—A regulated investment company as defined in section 851 or an entity registered at all times during the tax year under the Investment Company Act of 1940

I—A common trust fund as defined in section 584(a)

J—A bank as defined in section 581

K—A broker

L—A trust exempt from tax under section 664 or described in section 4947(a)(1)

M—A tax exempt trust under a section 403(b) plan or section 457(g) plan

Note: You may wish to consult with the financial institution requesting this form to determine whether the FATCA code and/or exempt payee code should be completed.

Line 5

Enter your address (number, street, and apartment or suite number). This is where the requester of this Form W-9 will mail your information returns. If this address differs from the one the requester already has on file, write NEW at the top. If a new address is provided, there is still a chance the old address will be used until the payor changes your address in their records.

Line 6

Enter your city, state, and ZIP code.

Part I. Taxpayer Identification Number (TIN)

Enter your TIN in the appropriate box. If you are a resident alien and you do not have and are not eligible to get an SSN, your TIN is your IRS individual taxpayer identification number (ITIN). Enter it in the social security number box. If you do not have an ITIN, see *How to get a TIN* below.

If you are a sole proprietor and you have an EIN, you may enter either your SSN or EIN.

If you are a single-member LLC that is disregarded as an entity separate from its owner, enter the owner's SSN (or EIN, if the owner has one). Do not enter the disregarded entity's EIN. If the LLC is classified as a corporation or partnership, enter the entity's EIN.

Note: See *What Name and Number To Give the Requester*, later, for further clarification of name and TIN combinations.

How to get a TIN. If you do not have a TIN, apply for one immediately. To apply for an SSN, get Form SS-5, Application for a Social Security Card, from your local SSA office or get this form online at www.SSA.gov. You may also get this form by calling 1-800-772-1213. Use Form W-7, Application for IRS Individual Taxpayer Identification Number, to apply for an ITIN, or Form SS-4, Application for Employer Identification Number, to apply for an EIN. You can apply for an EIN online by accessing the IRS website at www.irs.gov/Businesses and clicking on Employer Identification Number (EIN) under Starting a Business. Go to www.irs.gov/Forms to view, download, or print Form W-7 and/or Form SS-4. Or, you can go to www.irs.gov/OrderForms to place an order and have Form W-7 and/or SS-4 mailed to you within 10 business days.

If you are asked to complete Form W-9 but do not have a TIN, apply for a TIN and write "Applied For" in the space for the TIN, sign and date the form, and give it to the requester. For interest and dividend payments, and certain payments made with respect to readily tradable instruments, generally you will have 60 days to get a TIN and give it to the requester before you are subject to backup withholding on payments. The 60-day rule does not apply to other types of payments. You will be subject to backup withholding on all such payments until you provide your TIN to the requester.

Note: Entering "Applied For" means that you have already applied for a TIN or that you intend to apply for one soon.

Caution: A disregarded U.S. entity that has a foreign owner must use the appropriate Form W-8.

Part II. Certification

To establish to the withholding agent that you are a U.S. person, or resident alien, sign Form W-9. You may be requested to sign by the withholding agent even if item 1, 4, or 5 below indicates otherwise.

For a joint account, only the person whose TIN is shown in Part I should sign (when required). In the case of a disregarded entity, the person identified on line 1 must sign. Exempt payees, see *Exempt payee code*, earlier.

Signature requirements. Complete the certification as indicated in items 1 through 5 below.

1. Interest, dividend, and barter exchange accounts opened before 1984 and broker accounts considered active during 1983.

You must give your correct TIN, but you do not have to sign the certification.

2. Interest, dividend, broker, and barter exchange accounts opened after 1983 and broker accounts considered inactive during 1983.

You must sign the certification or backup withholding will apply. If you are subject to backup withholding and you are merely providing your correct TIN to the requester, you must cross out item 2 in the certification before signing the form.

3. Real estate transactions.

You must sign the certification. You may cross out item 2 of the certification.

4. Other payments.

You must give your correct TIN, but you do not have to sign the certification unless you have been notified that you have previously given an incorrect TIN. "Other payments" include payments made in the course of the requester's trade or business for rents, royalties, goods (other than bills for merchandise), medical and health care services (including payments to corporations), payments to a nonemployee for services, payments made in settlement of payment card and third party network transactions, payments to certain fishing boat crew members and fishermen, and gross proceeds paid to attorneys (including payments to corporations).

5. Mortgage interest paid by you, acquisition or abandonment of secured property, cancellation of debt, qualified tuition program payments (under section 529), ABLE accounts (under section 529A), IRA, Coverdell ESA, Archer MSA or HSA contributions or distributions, and pension distributions.

You must give your correct TIN, but you do not have to sign the certification.

What Name and Number To Give the Requester

For this type of account:	Give name and SSN of:
1. Individual	The individual
2. Two or more individuals (joint account) other than an account maintained by an FFI	The actual owner of the account or, if combined funds, the first individual on the account ¹
3. Two or more U.S. persons (joint account maintained by an FFI)	Each holder of the account
4. Custodial account of a minor (Uniform Gift to Minors Act)	The minor ²
5. a. The usual revocable savings trust (grantor is also trustee)	The grantor-trustee ¹
b. So-called trust account that is not a legal or valid trust under state law	The actual owner ¹
6. Sole proprietorship or disregarded entity owned by an individual	The owner ³
7. Grantor trust filing under Optional Form 1099 Filing Method 1 (see Regulations section 1.671-4(b)(2)(i)(A))	The grantor*
For this type of account:	Give name and EIN of:
8. Disregarded entity not owned by an individual	The owner
9. A valid trust, estate, or pension trust	Legal entity ⁴
10. Corporation or LLC electing corporate status on Form 8832 or Form 2553	The corporation
11. Association, club, religious, charitable, educational, or other tax-exempt organization	The organization
12. Partnership or multi-member LLC	The partnership
13. A broker or registered nominee	The broker or nominee

For this type of account:	Give name and EIN of:
14. Account with the Department of Agriculture in the name of a public entity (such as a state or local government, school district, or prison) that receives agricultural program payments	The public entity
15. Grantor trust filing under the Form 1041 Filing Method or the Optional Form 1099 Filing Method 2 (see Regulations section 1.671-4(b)(2)(i)(B))	The trust

¹ List first and circle the name of the person whose number you furnish. If only one person on a joint account has an SSN, that person's number must be furnished.

² Circle the minor's name and furnish the minor's SSN.

³ You must show your individual name and you may also enter your business or DBA name on the "Business name/disregarded entity" name line. You may use either your SSN or EIN (if you have one), but the IRS encourages you to use your SSN.

⁴ List first and circle the name of the trust, estate, or pension trust. (Do not furnish the TIN of the personal representative or trustee unless the legal entity itself is not designated in the account title.) Also see *Special rules for partnerships*, earlier.

*Note: The grantor also must provide a Form W-9 to trustee of trust.

Note: If no name is circled when more than one name is listed, the number will be considered to be that of the first name listed.

Secure Your Tax Records From Identity Theft

Identity theft occurs when someone uses your personal information such as your name, SSN, or other identifying information, without your permission, to commit fraud or other crimes. An identity thief may use your SSN to get a job or may file a tax return using your SSN to receive a refund.

To reduce your risk:

- Protect your SSN,
- Ensure your employer is protecting your SSN, and
- Be careful when choosing a tax preparer.

If your tax records are affected by identity theft and you receive a notice from the IRS, respond right away to the name and phone number printed on the IRS notice or letter.

If your tax records are not currently affected by identity theft but you think you are at risk due to a lost or stolen purse or wallet, questionable credit card activity or credit report, contact the IRS Identity Theft Hotline at 1-800-908-4490 or submit Form 14039.

For more information, see Pub. 5027, Identity Theft Information for Taxpayers.

Victims of identity theft who are experiencing economic harm or a systemic problem, or are seeking help in resolving tax problems that have not been resolved through normal channels, may be eligible for Taxpayer Advocate Service (TAS) assistance. You can reach TAS by calling the TAS toll-free case intake line at 1-877-777-4778 or TTY/TDD 1-800-829-4059.

Protect yourself from suspicious emails or phishing schemes.

Phishing is the creation and use of email and websites designed to mimic legitimate business emails and websites. The most common act is sending an email to a user falsely claiming to be an established legitimate enterprise in an attempt to scam the user into surrendering private information that will be used for identity theft.

The IRS does not initiate contacts with taxpayers via emails. Also, the IRS does not request personal detailed information through email or ask taxpayers for the PIN numbers, passwords, or similar secret access information for their credit card, bank, or other financial accounts.

If you receive an unsolicited email claiming to be from the IRS, forward this message to phishing@irs.gov. You may also report misuse of the IRS name, logo, or other IRS property to the Treasury Inspector General for Tax Administration (TIGTA) at 1-800-366-4484. You can forward suspicious emails to the Federal Trade Commission at spam@uce.gov or report them at www.ftc.gov/complaint. You can contact the FTC at www.ftc.gov/idtheft or 877-IDTHEFT (877-438-4338). If you have been the victim of identity theft, see www.IdentityTheft.gov and Pub. 5027.

Visit www.irs.gov/IdentityTheft to learn more about identity theft and how to reduce your risk.

Privacy Act Notice

Section 6109 of the Internal Revenue Code requires you to provide your correct TIN to persons (including federal agencies) who are required to file information returns with the IRS to report interest, dividends, or certain other income paid to you; mortgage interest you paid; the acquisition or abandonment of secured property; the cancellation of debt; or contributions you made to an IRA, Archer MSA, or HSA. The person collecting this form uses the information on the form to file information returns with the IRS, reporting the above information. Routine uses of this information include giving it to the Department of Justice for civil and criminal litigation and to cities, states, the District of Columbia, and U.S. commonwealths and possessions for use in administering their laws. The information also may be disclosed to other countries under a treaty, to federal and state agencies to enforce civil and criminal laws, or to federal law enforcement and intelligence agencies to combat terrorism. You must provide your TIN whether or not you are required to file a tax return. Under section 3406, payers must generally withhold a percentage of taxable interest, dividend, and certain other payments to a payee who does not give a TIN to the payer. Certain penalties may also apply for providing false or fraudulent information.

PROOF OF INSURANCE

This is to certify that the following endorsement is part of the policy(ies) described below:

NAMED INSURED (CONTRACTOR)	<u>COMPANIES AFFORDING COVERAGE</u>
ADDRESS	A. B. C.

It is hereby understood and agreed that the city of Owosso, its city council and each member thereof and every officer and employee of the city shall be named as joint and several assureds with respect to claims arising out of the following project:

2021 WATER SERVICE LINE REPLACEMENT PROJECT

It is further agreed that the following indemnity agreement between the city of Owosso and the named insured is covered under this policy: Contractor agrees to indemnify, hold harmless and defend city, its city council and each member thereof and every officer and employee of city from any and all liability or financial loss resulting from any suits, claims, losses or actions brought against and from all costs and expenses of litigation brought against city, its city council and each member thereof and any officer or employee of city which results directly or indirectly from the wrongful or negligent actions of contractor's officers, employees, agents or others employed by Contractor while engaged by contractor in the (performance of this agreement) construction of this project.

It is further agreed that the inclusion of more than one assured shall not operate to increase the limit of the company's liability and that insurer waives any right on contribution with insurance which may be available to the city of Owosso.

The contractor, or any of their subcontractors, shall not commence work under this contract until they have attained the insurance required below, and shall keep such insurance in force during the entire life of this contract. All coverage shall be with insurance companies licensed and admitted to do business in the State of Michigan and acceptable to the city of Owosso. The requirements below should not be interpreted to limit the liability of the Contractor. All deductibles and SIR's are the responsibility of the Contractor.

The Contractor shall procure and maintain the following insurance coverage:

1. **Worker's Compensation Insurance** including Employers' Liability Coverage, in accordance with all applicable statutes of the State of Michigan.
2. **Commercial General Liability Insurance** on an "Occurrence Basis" with limits of liability not less than \$1,000,000 per occurrence and aggregate. Coverage shall include the following extensions: (A) Contractual Liability; (B) Products and Completed Operations; (C) Independent Contractors Coverage; (D) Broad Form General Liability Extensions or equivalent, if not already included.
3. **Automobile Liability** including Michigan No-Fault Coverages, with limits of liability not less than \$1,000,000 per occurrence, combined single limit for Bodily Injury, and Property Damage. Coverage shall include all owned vehicles, all non-owned vehicles, and all hired vehicles.
4. **Additional Insured:** Commercial General Liability and Automobile Liability, as described above, shall include an endorsement stating the following shall be **Additional Insureds:** City of Owosso, all elected and appointed officials, all employees and volunteers, all boards, commissions, and/or authorities

and board members, including employees and volunteers thereof. It is understood and agreed by naming City of Owosso as additional insured, coverage afforded is considered to be primary and any other insurance the city of Owosso may have in effect shall be considered secondary and/or excess.

5. Cancellation Notice: All policies, as described above, shall include an endorsement stating that it is understood and agreed that a Ten (10) days' notice for non-payment of premium is required and a Thirty (30) days' notice is required for Non-Renewal, Reduction, and/or Material Change, shall be sent to: City of Owosso, Bid Coordinator, 301 W. Main Street, Owosso, Michigan 48867.

6. Proof of Insurance Coverage: The Contractor shall provide the city of Owosso, at the time that the contracts are returned by him/her for execution, a Certificate of Insurance as well as the required endorsements. In lieu of required endorsements, if applicable, a copy of the policy sections where coverage is provided for additional insured and cancellation notice would be acceptable. Copies or certified copies of all policies mentioned above shall be furnished, if so requested.

If any of the above coverages expire during the term of this contract, the Contractor shall deliver renewal certificates and endorsements to the city of Owosso at least ten (10) days prior to the expiration date.

Please include a copy of insurance declaration verifying amounts of coverage. The verification of insurance is not an insurance policy and does not amend, extend or alter the coverage afforded by the policies listed herein. Notwithstanding any requirement, term, or condition of any contract or other document with respect to which this certificate or verification of insurance may be issued or may pertain, the insurance afforded by the policies described herein is subject to all the terms, exclusions and conditions of such policies.

DATE _____

BY _____
Authorized Insurance Agent

AGENCY _____

TITLE _____

ADDRESS _____

PROGRESS CLAUSE

1 of 1

2021 WATER SERVICE LINE REPLACEMENT PROJECT

Work is to start as soon as weather permits after receiving the Notice to Proceed. No work shall commence until the Notice to Proceed is issued. **The completion date for all work is August 6, 2021.**

The Contractor is required to coordinate work with the following criteria:

- 1. No work shall begin before June 21, 2021**
- 2. The service line replacements on Garfield, Pearce, Glenwood, and Park must be completed before service lines on other streets.**
- 3. All work must be completed on or before August 6, 2021.**
- 4. Reasonable access must be maintained for residents and vehicular traffic.**

The contractor must build sufficient work days into the schedule to ensure all necessary work is completed on or before the completion date.

The approved successful bidder for the work covered by this proposal is required to participate in a pre-construction meeting with the city to review and work out a detailed progress schedule. The meeting will occur soon after the successful bidder is determined. Any named sub-contractors should also attend the scheduled meeting.

CITY OF OWOSSO
SPECIAL PROVISION
FOR
MAINTAINING TRAFFIC

City of Owosso/CW

Page 1 of 3

12/2/2020

DESCRIPTION

Traffic shall be maintained by the Contractor throughout the project in accordance with Section 104.07, 104.11, 812 and 922 of the MDOT 2012 Standard Specifications and in accordance with any Supplemental Specifications, the MDOT Maintaining Traffic Typical and as specified herein. All traffic control devices shall conform to the 2011 Michigan Manual of Uniform Traffic Control Devices (MMUTCD).

The Contractor shall notify all emergency response, road commission, municipalities, school bus garages or other necessary agencies a minimum of three days prior to implementing a road closure.

The Contractor shall coordinate his operations with other Contractors or Utility owners performing work on other projects within or adjacent to the Construction Influence Area (CIA) or adjoining areas to avoid conflicts in maintenance of traffic, construction signing and to provide for the orderly progress of work.

The Contractor shall provide access at all times during construction for school buses, garbage trucks, and any other service vehicles required to traverse and service residences within the construction area.

The Contractor shall obtain MDOT permits for any work on M-71 (Corunna Avenue), M-52 (Shiawassee Street), and M-21 (Main Street).

The Michigan Department of Transportation (MDOT), the Shiawassee County Road Commission and the City of Owosso maintenance crews and/or Contract Maintenance Agencies may perform maintenance work within or adjacent to the CIA. No additional payment will be made to the Contractor for the joint use of traffic control items.

CONSTRUCTION INFLUENCE AREA (CIA)

The CIA shall include the right of ways of the list streets in the City of Owosso within the extents of the work indicated on the plans, including all intersecting access, and as far as the advanced signing is required to accommodate all traffic control devices.

The Contractor shall notify the Engineer and property owners a minimum of 48 hours in advance of driveway work / closure. The Contractor shall maintain driveway access throughout the entire project during construction. Driveways that are to be removed and replaced shall be maintained with Maintenance Gravel and shall be constructed as part width.

CITY OF OWOSSO
SPECIAL PROVISION
FOR
MAINTAINING TRAFFIC

City of Owosso/CW

Page 2 of 3

12/2/2020

The Contractor shall maintain pedestrian access throughout the entire project at all times during construction. Areas of sidewalk that are to be removed and replaced shall be maintained with Maintenance Gravel. Pedestrian access to all residences, churches, and businesses shall be allowed at all times.

The Contractor shall maintain access to all adjacent property locations at all times. Temporary ramps for sidewalks, ramps, and driveways shall be constructed as directed by the Engineer, and the cost shall be included in the Water Service Pay Items.

Barricades used to control traffic at night shall be lighted.
Drums used shall be plastic drums or channelizing devices.

Signs shall be Type B temporary with a 7-foot bottom height, unless otherwise directed by the Engineer.

Maintaining Traffic includes all additional work and materials necessary for traffic maintenance, utility maintenance and coordination, and maintenance during construction for all items of work.

TRAFFIC RESTRICTIONS

Changes or adjustments in the signing provided may be necessary as determined by the Engineer.

The Contractor may not work after dark unless approved by the Engineer and adequate lighting is provided. Working hours are 7 am to 7 pm.

No work shall be allowed during holiday periods as established by MDOT.

No weekend work shall be allowed.

Contractor shall backfill any trenches prior to the end of the work day, no open trenches will be allowed overnight.

Traffic shall be maintained in accordance to the following MDOT Maintaining Traffic Typical while impacting traffic within MDOT ROW:

- WZD-100-a
- WZD-125-e
- M0020a
- M0040a
- M0110a
- M0140a

CITY OF OWOSSO
SPECIAL PROVISION
FOR
MAINTAINING TRAFFIC

City of Owosso/CW

Page 3 of 3

12/2/2020

All local noise and dust control ordinances shall apply to this project.

MEASUREMENT AND PAYMENT

The work of maintaining traffic shall be considered incidental to the project work and not paid for separately.

CITY OF OWOSSO
SPECIAL PROVISION
FOR
HMA, Repair

City of Owosso/CW

Page 1 of 1

12/2/2020

DESCRIPTION

This work shall be done in accordance with Section 302 and 501 of the MDOT 2012 Standard Specifications for Construction and as specified herein.

CONSTRUCTION

Work shall include the furnishing, placement, grading, and compaction of HMA and/or aggregate to achieve the proposed section at the locations shown in plan.

The material to be used for HMA, Repair shall be:

HMA, 13A, placed in a maximum of 275 lbs/syd per lift till it matches existing pavement.

Aggregate Base shall be 8 inches of 21AA crushed limestone aggregate. Existing base material and any added aggregate base shall be compacted in place to 95% Maximum Density.

MEASUREMENT AND PAYMENT

The completed work as measured for HMA, Repair will be paid for at the contract unit price for the following contract item (pay item):

<u>Pay Item</u>	<u>Pay Unit</u>
HMA, Repair	Ton

HMA, Repair shall be payment in full for material, labor, and equipment needed to accomplish the work.

Placement of 21AA crushed limestone shall be considered incidental to the work of HMA, Repair and will not be paid for separately.

CITY OF OWOSSO
SPECIAL PROVISION
FOR
SIDEWALK, CONC, __ INCH, MODIFIED

City of Owosso/CW

Page 1 of 1

12/2/2020

DESCRIPTION

This work shall consist of placing concrete sidewalk where shown on the plans or as directed by the Engineer and shall be in accordance with Section 803 of the MDOT 2012 Standard Specifications for Construction and as specified herein.

CONSTRUCTION METHODS

The sidewalk pay item shall include furnishing, placement and compaction of the sand base to a minimum depth of 4 inches compacted in place to 95% Maximum Density, prior to concrete placement. Work includes all excavation, compaction, reinforcing steel, sawing if required, proper placement of sidewalk material and expansion material as required.

The material to be used for Sidewalk shall be:

Concrete – Uniform, Grade P1, 3500 PSI, 6 sack mix, Air Entrained.
Sand base shall meet requirements of Granular Material Class II, Section 902 of the MDOT 2012 Standard Specifications for Construction.

MEASUREMENT AND PAYMENT

The completed work as measured for Sidewalk will be paid for at the contract unit price for the following contract item (pay item):

<u>Pay Item</u>	<u>Pay Unit</u>
Sidewalk, Conc, __ inch, Modified	Square Foot

Pay Items will be measured by area in square feet and will be paid for at the contract unit price per square foot which price shall be payment in full for material, labor, and equipment needed to accomplish the work including furnishing, placing, and compacting the sand base.

CITY OF OWOSSO
SPECIAL PROVISION
FOR
Sidewalk, Rem / HMA, Rem

City of Owosso/CW

Page 1 of 1

12/2/2020

DESCRIPTION

Pavement and sidewalk removal shall be performed in accordance with Section 204 of the 2012 MDOT Standard Specifications for Construction, except as specified herein.

The Contractor shall remove pavement and sidewalk of whatever material or thickness or multiple layers that may be encountered. Pavement removal shall be to an existing joint or to a sawed joint as shown on plans or as directed by the Engineer.

MEASUREMENT AND PAYMENT

Removing pavement and sidewalk will be paid for at the contract unit prices for the following pay items and shall include all labor, equipment and materials to complete the work.

<u>Pay Item</u>	<u>Pay Unit</u>
Sidewalk, Rem.	Square Yard
HMA, Rem.	Square Yard

Payment for saw cutting, if required, will be included in the related removal pay items and will not be paid for separately.

Materials or debris resulting from pavement removal shall become the property of the Contractor and disposed of in accordance with Subsection 204.03.B of the 2012 MDOT Standard Specifications for Construction.

The contract unit price will be compensation for removing pavement of whatever material and thicknesses are encountered.

CITY OF OWOSSO
SPECIAL PROVISION
FOR
SUBGRADE UNDERCUTTING, TYPE II, MODIFIED

City of Owosso/CW

Page 1 of 1

12/2/2020

DESCRIPTION

The work shall be done in accordance with the requirements of the Michigan Department of Transportation 2012 Standard Specifications for Construction Section 205 except as specified herein.

CONSTRUCTION

If areas of peat are exposed and directed to be undercut by the Engineer, the undercut shall follow the requirements of the Michigan Department of Transportation 2012 Standard Specifications Section 205, with the exception that the material undercut shall include peat.

MEASUREMENT AND PAYMENT

The complete work as measured for Subgrade Undercutting, Type II, Modified will be paid for at the contract unit price for the following contract pay items and includes all material, equipment, labor, aggregate, compaction and material disposal to complete the items.

<u>Pay Item</u>	<u>Pay Unit</u>
Subgrade Undercutting, Type II, Modified	Cubic Yard

Areas of subgrade undercutting shall be verified and approved by Engineer prior to work being completed. Any undercut operations performed without approval from Engineer shall not be paid for.

MICHIGAN
DEPARTMENT OF TRANSPORTATION

SPECIAL PROVISION
FOR
TURF ESTABLISHMENT, PERFORMANCE

RSD:JLB

1 of 6

APPR:DMG:KJS:05-13-20

a. Description. For the work specified in this special provision paid for by the pay item Turf Establishment, Performance only, delete section 816 of the Standard Specifications for Construction and replace it with this special provision. The Contractor is responsible for the performance and quality of turf growth in the areas shown on the plans and as identified by the Engineer. Comply with all local, state and federal laws when completing this work.

Establish a durable, permanent, mature, perennial turf. The work consists of fundamental turf work, including but not limited to topsoiling, seeding, mulching, erosion control, maintenance, watering and repair of turf as described herein during the life of the contract and during the life of any supplemental performance bond which may ensue.

Choose and implement proven turf establishment industry practices; provide all necessary labor and equipment; select and provide all turf establishment materials; and control erosion and any subsequent sedimentation at all times.

Perform a site analysis, interpret the results and implement a turf establishment program to ensure compliance with this specification. The site analysis must take into consideration topsoil needs, fertilizer and pH requirements, seed mix, existing and future soil moisture levels, slopes and grades, required erosion control measures, maintenance requirements, local highway snow removal and deicing practices, and any other characteristics that influence and affect turf establishment.

Subsection 107.11 of the Standard Specifications for Construction is revised relative to the Contractor's responsibility for the repair of turf establishment work as follows. The Contractor is responsible, at no additional cost to the contract, for the repair of turf establishment work occasioned by storm events up to 3 inches of rain in a 24 hour period as documented by local meteorological data submitted to the Engineer for review and approval. All other portions of subsection 107.11 remain unchanged.

1. Contractor Turf Establishment Experience Requirements. Ensure weed control is done by a commercial herbicide applicator, licensed by the State of Michigan and certified by the Michigan Department of Agriculture & Rural Development (MDARD) in the appropriate category to apply herbicides. Use application procedures and materials in accordance with federal, state and local regulations. Use of restricted use chemicals is prohibited. Provide appropriate documentation and secure approval from the Engineer before application of herbicides.

At least 10 work days prior to the start of turf establishment, provide documentation to the Engineer, from the Contractor performing the turf establishment work, that they meet one or both of the following requirements.

A. At least one person employed by the Contractor performing the turf establishment work and assigned to the job site has a degree or certificate in Turf Management, Horticulture or related field.

B. At least one person employed by the Contractor performing the turf establishment work and assigned to the job site has at least 5 years of experience in roadside turf establishment.

b. Materials. Provide topsoil, seed, mulch, pesticide, herbicide, mulch blanket and any other unique erosion control materials as necessary to fulfill this specification, as shown on the plans. Use additional materials, as necessary, to meet the standards set forth for turf establishment in this special provision. The use of sod on the project requires the prior approval of the Engineer and if approved, may be used at limited site locations only.

Selection of all materials is the responsibility of the Contractor with the following minimum conditions.

1. Soil. Provide furnished or salvaged topsoil, which may be blended compost, that will support vigorous growth. Ensure topsoil is humus bearing and placed at least 4 inches deep. Ensure it is free of stones larger than 1/2 inch (2 inches on freeway projects) in diameter and other debris. Trim and grade the finished slope in accordance with subsection 205.03.N of the Standard Specifications for Construction.

2. Seed. Use a seeding mixture that is composed of four or more species of perennial grass. Use only species and their cultivars or varieties which are guaranteed hardy for Michigan.

Recommended species of perennial grasses include Kentucky Bluegrass, Perennial Ryegrass, Hard Fescue, Creeping Red Fescue, Chewings Fescue, Turf-type Tall Fescue, Buffalo grass, and Alkaligrass-Fulfs Puccinellia distans. Select cultivars or varieties of grasses that are disease and insect resistant and of good color. Ensure that no one species in the mix is less than 5 percent, or more than 25 percent, of the mixture by weight. Do not select grass species considered noxious or objectionable, such as Quack Grass, Smooth Brome, Orchard Grass, Reed Canary Grass and others.

A. Ensure the seed is legally saleable in Michigan. Ensure the seed product does not contain more than 10 percent inert materials. Ensure the seed source is an MDOT approved certified vender.

B. Adapt the species and varieties of seed to the site conditions, to the site use, and to the soils, moisture and local climate. Site use may include, but is not limited to, detention pond, wildlife habitat, playground, wetlands, forested wetland, rural roadside, urban roadside and highly maintained front yard.

C. Ensure at least two of the species in the mixture proposed to be planted within 15 feet behind the curb or the shoulder are salt tolerant.

3. Mulch. Mulch seeded areas with the appropriate materials for the site conditions to promote germination and growth of seed and to mitigate soil erosion and sedimentation.

4. Herbicides. Comply with all federal, state and local laws. As part of the MDARD weed

control application, the Contractor is required to make proper notifications and postings in accordance with the label and MDARD requirements for all locations that will be sprayed. Notify the Engineer at least 48 hours prior to any applications being made. Furnish and apply herbicide(s) as needed. It is the Contractor's responsibility to select the herbicide(s) and the rate at which it is used. Obtain the Engineer's approval of work methods and herbicide(s) selected prior to the application of the herbicide(s). Complete a spray log and submit to the Engineer each day an application is made.

Do not draw water from any waterway (i.e. river, ditch, creek, lake etc.) located on state, county or municipal right-of-way, for mixing with herbicides.

5. Fertilizers. Furnish and apply fertilizer(s) as needed. It is the Contractor's responsibility to select the fertilizer(s) and the rate at which it is used. Phosphorus is allowed for use only at the time of planting and when required by soil conditions. Obtain the Engineer's approval of work methods and fertilizer(s) prior to the application of the fertilizer(s).

6. Water. Furnish and apply water from an approved source at a rate to promote healthy growth.

c. Construction. The Contractor is responsible for all work and all construction methods used in completing this work. Implementation of any part of the standard specifications or standard plans by the Contractor does not relieve the Contractor of responsibility for acceptability of the construction methods or for the quality of the work.

1. Inspection of the Work. The Contractor is responsible for all inspection of turf establishment work.

Use a Contractor's Daily Report, approved by the Engineer, to report inspections made and to document turf establishment work performed on this project. Complete and submit a Contractor's Daily Report to the Engineer when any work performed under this special provision is in progress.

Include all necessary materials documentation including tests slips, certifications, etc. with the associated Contractor's Daily Report.

The Engineer will determine the acceptability of the Contractor's Daily Report in terms of the completeness and accuracy. The Engineer reserves the right to verify all submitted measurements and computations. Failure by the Contractor to submit acceptable and timely reports to the Engineer may result in withholding of progress pay estimates on turf-related items until such time as reports are submitted and deemed acceptable.

The Engineer reserves the right to inspect the project for any reason in accordance with subsection 104.01 of the Standard Specifications for Construction, including the fulfillment of other inspection requirements such as Soil Erosion and Sedimentation Control, NPDES, etc. Inspections made by the Engineer do not relieve the Contractor of the responsibility for inspections required by this special provision or the Contractor's responsibilities for erosion control and turf establishment.

2. Erosion Control. Control erosion at all times in accordance with section 208 of the Standard Specifications for Construction. Control of soil erosion is the responsibility of the Contractor. However, ensure sedimentation controls are placed as shown on the plans or as

directed by the Engineer. Continuously monitor the site for needed erosion repair from any cause as addressed in the contract. Return all eroded areas to original grade as detailed in the contract.

Take immediate corrective action if sedimentation occurs in drainage structures or any watercourse or water containment area and stabilize all disturbed areas contributing to this sedimentation within 24 hours after the erosion occurrence. Remove sediment deposited as a result of the Contractor's inability to control the soil erosion at the Contractor's expense.

Reimburse the Department for any costs levied against the Department, such as fines, environmental costs, costs for remedies required, or any other costs as a result of the Contractor's failure to comply with this special provision and with federal, state and local laws.

3. Erosion Repair. The Contractor is responsible for all repairs and liable for all consequences (legal, monetary or other) associated with erosion or sedimentation damage to finished or unfinished work.

Report all erosion occurrences and the repairs made by the Contractor to the Engineer in the format and at the frequency required by the Engineer. Repair any erosion, displacement or disturbance to ongoing or completed work by any cause at no additional cost to the contract unless otherwise noted herein.

The Contractor is responsible and liable for all traffic control and safety measures required to repair and protect damaged turf areas. Repair any eroded area that may affect the support of the roadbed or safety of the public within 24 hours of the erosion occurrence.

Place protective devices such as barriers, directional signs/signals, temporary fence, or any other safety measures immediately after any erosion damage occurs that has the potential of endangering the public. In these instances, provide the Engineer with a written summary of the immediate action taken describing the repairs made and the safety measures taken, within 24 hours of the occurrence of the damage.

4. Mowing and Weeding. Maintain turf to a visually appealing level, and not more than 8 inches in height at any time, prior to acceptance. Weeds must be controlled to less than 10 percent of the turf establishment area at all times during construction.

5. Final Acceptance and Supplemental Performance Bond.

A. Final Acceptance Parameters. Ensure before final acceptance of the turf establishment work, all of the following minimum parameters are met throughout all exposed areas of the project designated on the plans or identified by the Engineer as turf establishment areas: there must be no exposed bare soil and the turf must be fully germinated, erosion free, weeds less than 10 percent, disease free, dark green in color and in a vigorous growing condition.

The Engineer will notify the Contractor of the dates and times of all acceptance inspections. The Contractor may accompany the Engineer during these inspections. If the Contractor does not agree with the decision made by the Engineer, the Contractor may request an inspection by a mutually agreed upon third party (Michigan State University Extension service or other). A joint inspection, to include the Engineer, the Contractor, and the third party, will be scheduled by the Engineer. Pay all expert fees and

expenses charged by the third party.

B. Supplemental Performance Bond. In the event that all contract items of work are completed, including the placement of all turf establishment items of work, and the final acceptance of the project is delayed because the final acceptance parameters for the turf establishment work have not been fully met; the Contractor may propose to the Engineer the use of a supplemental performance bond.

The bond serves to secure the successful completion of turf establishment work and fulfillment of all final acceptance parameters for the turf establishment work. Ensure the supplemental performance bond, in all respects, is satisfactory and acceptable to the Department and executed by a surety company authorized to do business with the State of Michigan.

Ensure the bond is in an amount equal to 50 percent of the turf establishment work items covered by this special provision. Ensure the bond remains in place for two growing seasons. At the discretion of the Engineer, the bond may be reduced on a prorated basis as portions of the areas designated for turf establishment on the project meet the final acceptance parameters.

Prior to commencement of any work necessary to meet the acceptance parameters during the bonded period, the Contractor must apply for a permit to work within the right-of-way through the [MDOT Permit Gateway](#). The permit fee and an individual permit performance bond will not be required. The permit insurance requirements, however, will be required.

d. **Measurement and Payment.** The completed work, as described, will be measured and paid for at the contract unit price using the following pay item:

Pay Item	Pay Unit
Turf Establishment, Performance	Square Yard

Turf Establishment, Performance includes installing, maintaining, inspecting, repairing and meeting the acceptance parameters for turf establishment specified in this special provision, including preparation, updating and submittal of the Contractor's Daily Reports.

Repairs made to damaged turf establishment areas as a result of a documented storm by local meteorological data resulting in rainfall amounts of more than 3 inches in a 24 hour period will be paid for as an increase to original quantities in accordance with subsection 109.05 of the Standard Specifications for Construction.

The following schedule of payment applies to work performed in accordance with this special provision. Upon completion of topsoil surfacing stage, 50 percent of the authorized amount for **Turf Establishment, Performance** will be paid to the Contractor. The remaining 50 percent of the authorized amount will be paid upon completion of all other work necessary to comply with this special provision and to meet all final acceptance parameters for **Turf Establishment, Performance** or at such time as the supplemental performance bond is accepted by the Department.

The supplemental performance bond and all costs associated with turf establishment work performed during the duration of the performance bond will not be paid for separately. These

costs which may include, but are not limited to, mobilization, traffic control devices, and the required permit insurance are included in the unit price bid for **Turf Establishment, Performance.**

**CITY OF OWOSSO
SPECIAL PROVISION
FOR
WATER SERVICE LINE INSTALLATION**

City of Owosso/CW

Page 1 of 9

4/9/2021

DESCRIPTION

This work shall consist of installing water main and appurtenances in accordance with the plans, this special provision, AWWA, MDEQ, and the MDOT 2012 Standard Plans and Specifications. This shall include all labor, equipment, and materials to complete the work.

For the protection of underground utilities and in conformance with Public Act 174 of 2013, the Contractor shall contract the Miss Dig system, Inc. by phone at 811 or 800-482-7171 or via the web at either elocate.missdig.org for single address or rte.missdig.org, a minimum of 3 business days prior to excavation, excluding weekends and holidays.

The Department of Public Works can assist the Contractor in locating existing water service leads and mains. All removed valves and hydrants shall be salvaged and returned to the Department of Public Works.

The Contractor shall contact the Engineer to schedule work interfering with existing water service. Temporary shut off of service shall be obtained from the Department of Public Services.

A service charge of \$1,000 will be required at time of permit application. This fee includes the minimum charge of \$50 for 5,000 bulk gallons of water, plus additional charges of \$10 per 1,000 gallons consumed in excess of the minimum quantity. Owosso Water System personnel will attach a water meter and RPZ backflow preventer to the hydrant for Contractor use. If the water meter and RPZ is returned in good operating condition, the Contractor will receive a \$450 refund, less additional water consumed in excess of minimum quantity.

MATERIALS

All materials supplied by the Contractor shall be new, meeting minimum specifications of American Water Works Association (AWWA) Standards, and special provisions as delineated by the City of Owosso. All materials shall be lead free as defined by the USEPA Safe Drinking Water Act, in that; "All pipes, pipe fittings, plumbing fittings, and fixtures that are used for potable water must comply with the lead free requirement and must bear the mark NSF/ANSI Standard 61, Annex G or NSF 61-G."

Michigan and United States of America products shall be used whenever possible.

**CITY OF OWOSSO
SPECIAL PROVISION
FOR
WATER SERVICE LINE INSTALLATION**

City of Owosso/CW

Page 2 of 9

4/9/2021

Curb Stops/Boxes, Taps, and Services

The water service piping shall be 1” copper tubing, Type K, annealed, in accordance with ASTM B88. The fittings shall conform to ASTM B16.26, cast bronze. Joints of the copper tubing shall be flared. All water services to be constructed 90 degrees from water main to curb-stop/meter pit. 1” High Density (HD) PVC piping is acceptable for property side services.

Taps – Ductile Iron Pipe:

1. For ¾ inch residential service tap, no saddle required. Use Ford F-1000-3-Q-NL, taped thread x CTS – QJ (Note: 1-inch minimum now required)
2. For 1 inch residential service tap, no saddle required. Use Ford #F-1000-4-Q-NL
3. For larger than 1 inch service tap, use Ford #F series as appropriate.

Taps – PVC Pipe:

1. Use Power Seal stainless steel saddle Model 3417AS for 4” to 24” diameter pipe.

Clamps:

Use Ford Tapped Repair Clamps – FS1 – XXX - 12.5 - CC4 - SS. All clamps used must be stainless steel.

Curb stops/boxes shall follow below:

1. Curb Stops shall be manufactured by Ford, Model #B-44-333-Q-NL for ¾ inch ball- stop, and Model #B-44-444-Q-NL for 1 inch ball-stop. Female thread x CTS – QJ or CTS – QJ x CTS – QJ.
2. Curb Stops shall be 5’ 6” deep.
3. Curb Stop Boxes shall be the Standard Buffalo patterns and all parts of the same, including extension sections, shall be interchangeable and fit up with corresponding parts of other Standard Buffalo pattern boxes.
4. Internal diameter of base shaft shall be 2-1/2 inches for (¾ inch and 1 inch curb stop).
5. The boxes shall be cast iron, suitable coated to resist corrosion and the casting shall be smooth and free of any imperfections.
6. The covers shall overlap and fit outside the rim of the upper section, and they shall have a horseshoe-shaped groove in them to receive the bolt head and the word “water” embossed on the top surface.
7. All boxes shall be Tyler 6500 (2-1/2” Boxes) Series.

**CITY OF OWOSSO
SPECIAL PROVISION
FOR
WATER SERVICE LINE INSTALLATION**

City of Owosso/CW

Page 3 of 9

4/9/2021

Curb Stops/Boxes installed into concrete shall have a barrier/insulation material to keep the box and riser pipe from making contact with concrete to avoid movement from expansion. Barrier material shall be placed from the surface grade, and down through depth of concrete plus three (3) inches. Barrier material should be a minimum ¼ inch and not more than ½ inch thick. Material shall consist of a dense felt, rubber, or foam rubber suitable for exterior use.

Tracer Wire and Boxes

Tracer wire shall be #10 AWG polyethylene coated steel core copper wire, attached to pipe by tape or other approved means, and manufactured by Copperhead Industries, LLC – Copperhead Reinforced Tracer Wire, or equal. Tracer wire connectors must contain a dielectric waterproof and corrosion proof sealant, lock shut, and be color coded blue. (See MRWA Detail as Attached)

Tracer wire boxes shall be magnetized, with a direct connection to tracer wire without removing the cover, be color coded, and have a locking cover. Boxes shall be installed at every fire hydrant isolation valve (separate from the valve riser), and at every distribution water main isolation valve (separate from the valve riser) and shall be Copperhead Industries, LLC – Snake-Pit Magnetized Tracer Box, or equal.

**CITY OF OWOSSO
SPECIAL PROVISION
FOR
WATER SERVICE LINE INSTALLATION**

City of Owosso/CW

Page 4 of 9

4/9/2021

CONSTRUCTION METHODS

Methodology of Installation of Non-Standard (lead and/or galvanized) Water Service Lines

1. Non-standard (lead and galvanized pipe) water service lines may exist between the water main and the curb stop box or between the curb stop box and water meter located inside the house or in a meter pit outside the house/building. In other instances, the entire water service line from the water main to the meter consists of non-standard material. Except for excavation necessary to expose the water main and curb box, service lines shall be installed by use of trenchless technology methods otherwise approved by the engineer. The new service line shall be solid pipe not containing any splices. The method used for replacing the lead and galvanized services shall be by cable method, which involves the use of a cable placed inside the existing lead or galvanized service line with the new replacement copper line attached on the other side. The cable is then pulled using a winch or backhoe bucket to remove the old service line between the main and curb stop box and between the curb stop box and the building. If, in the opinion of the engineering, the old service line cannot be removed by the cable method, the new service line shall be installed by use of boring equipment. During the water service installation process, all valves service the house/building shall be turned off to prevent particles from entering the water system. Upon commencing work on any segment of a lead or galvanized service line, either from the water main to curb stop valve or from the curb stop valve to the building, neither segment of the water service line shall be used for water service until all segments of non-standard service line are replaced. All joints, fittings, and valve connections shall be exposed during a test period. The vendor will contact the engineer for an inspection to be performed to ensure that work has been done correctly and to properly record the work for the City's records.

**CITY OF OWOSSO
SPECIAL PROVISION
FOR
WATER SERVICE LINE INSTALLATION**

City of Owosso/CW

Page 5 of 9

4/9/2021

2. Replacement of Non-Standard Service Lines

A. Case #1: Non-Standard Service Line between the Curb Stop and Building

For non-standard lines located between the existing curb stop box and building, the contractor shall excavate the curb stop box, which typically located near the sidewalk or property line. The water service line inside the building on the inlet side of the water meter shall also be disconnected by the contractor. The opening in the wall at the location where the service line extends through the foundation of the building shall then be enlarged by the contractor if necessary. The new copper service line will then be installed between the building and curb stop box using the cable or other approved method. The contractor shall extend the new service line into the building and connect the line to the water meter. If it is necessary to use boring equipment to install the service line, the boring equipment shall bore through the foundation/basement wall of the structure and the old service line shall be abandoned on the inside of the basement wall by removing at least two (2) inches of the lead or galvanized service lines from within the basement wall, filling the interior of the remaining pipe with mortar. If it becomes necessary for the contractor to excavate on the outside of the building foundation to facilitate installation of the water service line, such work shall be completed in a manner that causes the least amount of disruption to yard areas and other locations near the building. The contractor will contact the engineer in order for an inspection to be performed to ensure that work has been done correctly and to properly record the work for the City's records.

B. Case #2: Non-Standard Service Lines between Water Main and Curb Stop Box

For non-standard service lines located between the water main and curb stop box, the contractor shall excavate the service line at two locations: at the water main, which is typically located beneath the street pavement, and the curb stop box, typically located near the sidewalk. The old service line will then be disconnected to at the water main and the curb stop and a new copper service line is then installed using cable or boring method. The new copper service line will then be connected to the existing water main using a stainless steel clamp with 1" opening placed over existing tap along with appropriate adaptors and fittings. If the existing corporation is determined to be unfit for re-use by the engineer, a new tap in the water main shall be made with a new corporation. If a standard service line (copper) existing between the curb stop box and the building, the contractor will connect the new service line to the existing curb stop after first flushing the new service line from the water main to curb stop.

**CITY OF OWOSSO
SPECIAL PROVISION
FOR
WATER SERVICE LINE INSTALLATION**

City of Owosso/CW

Page 6 of 9

4/9/2021

C. Case #3: Non-Standard Water Service Line between Water Main and Building

Where the entire water service line from the water main to the building consists of non-standard materials, the contractor shall follow the installation procedures described above and also install a new curb stop valve and curb stop box near the sidewalk at a location approved by the engineer. The contractor shall contact the engineer in order for an inspection to be performed to ensure that work has been done correctly and to properly record the work for the City's records. The partial replacement of non-standard water services is not allowed.

In all cases, prior to reconnecting the water meter, the new service line shall be thoroughly flushed with sufficient water volume and velocity to remove all foreign material from the pipe. If material within the pipe damages or plugs a customer's meter or service piping, the contractor shall be responsible for the cost of all repairs to the service line and related plumbing. After reconnection of the service line, an outside faucet shall be turned on for a period of at least two minutes to further flush any foreign material from the service line.

3. Excavation

The contractor shall furnish all labor, equipment, and materials necessary to expose all parts of the water service system necessary to replace the existing water service line. Except where otherwise approved by the Engineer, the contractor will cut pavement/sidewalk to an appropriate dimension to carry out the appropriate repair, and the excavation and installation process shall be performed in a manner to allow placement of new service lines at a final depth of five (5) to six (6) feet below finished grade regardless of the depth of the existing water service or water main. Except otherwise approved by the Engineer, all excavations necessary to complete the water service replacement (under roadways, curbs, driveways, approaches, and sidewalks) must follow the utility trench details and the Class II sand backfill must be compacted to 95% of the material's maximum density. All such excavations shall be capped off by placing 8 inches of 21AA crushed limestone matching the existing asphalt base course bottom elevation. Temporary restorations will be maintained at the contractor's expense until the contractor has performed final restoration. All excavations within the lawn/green belt areas are to be backfilled with the excavated materials, well graded, and free of any debris. These excavations will be filled to the level of the adjacent ground and left smooth. When weather permits, the top three (3) inches of backfill material shall be removed and three (3) inches of screened topsoil will be placed in the excavation. Seed and mulch shall be placed per manufacturer's recommendations.

**CITY OF OWOSSO
SPECIAL PROVISION
FOR
WATER SERVICE LINE INSTALLATION**

City of Owosso/CW

Page 7 of 9

4/9/2021

Notification to Residents of Water Service Shutdowns

1. In situations where the water supply needs to be shut down to make a new service connection tap, the Contractor shall give a minimum 48 hour notice for connection to potable water system.
2. The City will determine affected area of planned water supply service interruption, and send out notices 24 hours prior to planned water service interruption.
3. Prior to planned water supply shut off, Contractor shall have performed a thorough investigation and review of necessary parts and components adequately sized, and available on site at time of connection to the potable water supply, to avoid unnecessary lengthy water service interruptions to residents and businesses.

Scheduling of Service Line Replacements with Residents

1. The City will give the awarded contractor a list of the residents whose lines are to be replaced.
2. The contractor shall initiate communication with the resident to schedule a time for their water service line to be replaced that is satisfactory with the resident. The city will provide assistance as needed with getting contact information for the resident.
3. If the contractor is unable to establish communication with the resident, the contractor shall place a door hanger at the property owner's dwelling/business. The door hangers shall be approved by the City prior to their placement.
4. The contractor shall notify the City at least one week in advance of water service line replacement at each location.

Plumbing Inspections

1. For Case #1 and #3 Replacements, where a new water service line is connected inside the building, a licensed plumber shall be required to make the connection inside the building.
2. The licensed plumber shall obtain a plumbing permit and coordinate inspection with the City of Owosso Building Department. The plumbing permit fee is \$90 per location. The cost of the permit fee shall be included in part of related items.

**CITY OF OWOSSO
SPECIAL PROVISION
FOR
WATER SERVICE LINE INSTALLATION**

City of Owosso/CW

Page 8 of 9

4/9/2021

PAY ITEMS

The completed work of water main installation will be paid for at the contract unit prices for the actual quantity of the following contract items (pay items) actually constructed.

<u>Pay Items</u>	<u>PAY UNIT</u>
Water Service, Case 1, __ inch, Curb Stop to Water Meter	Ft
Water Service, Case 2, __ inch, Main to Curb Stop	Ft
Water Service, Case 3, __ inch, Full Service, Main to Meter	Ft
Failed Attempt, Cable Method	Ea
Failed Attempt, Boring Method	Ea
Water Main Tap	Ea

Payment for **Water Service, Case 1, __ inch, Curb Stop to Water Meter**: This shall include the installation of the copper water service lines and shall be paid at the contract unit price per foot of service line from the curb stop box to the water meter. The placement of this new copper water service line shall follow the method order written in the construction methods section. This item shall include all machinery, labor, and materials necessary to complete the installation of the copper water service line. This includes, but is not limited to, backfill, compaction, surface restoration of non-paved areas, coring and sealing the foundation walls, and excavation at the exterior of the foundation wall.

Payment for **Water Service, Case 2, __ inch, Main to Curb Stop**: This shall include the installation of the copper water service lines and shall be paid at the contract unit price per foot of service line from the water main to the curb stop box. The placement of this new copper water service line shall follow the method order written in the construction methods section. This item shall include all machinery, labor, and materials necessary to complete the installation of the copper water service line. This includes, but is not limited to, backfill, compaction, surface restoration of non-paved areas, coring and sealing the foundation walls, and excavation at the exterior of the foundation wall.

Payment for **Water Service, Case 3, __ inch, Full Service, Main to Meter**: This shall include the installation of the copper water service lines and shall be paid at the contract unit price per foot of service line from the water main to the water meter. The placement of this new copper water service line shall follow the method order written in the construction methods section. Replacement of the Curb Stop Box will be included into this payment item. This item shall include all machinery, labor, and materials necessary to complete the installation of the copper water service line and the replacement of the curb stop box. This includes, but is not limited to, backfill, compaction, surface restoration of non-paved areas, installation of new curb stop box, installation of new curb stop valve, coring and sealing the foundation walls, and excavation at the exterior of the foundation wall.

**CITY OF OWOSSO
SPECIAL PROVISION
FOR
WATER SERVICE LINE INSTALLATION**

City of Owosso/CW

Page 9 of 9

4/9/2021

Payment for **Failed Attempt, Cable Method**: This pay item is for when the attempt to replace the water service line using the “Cable Method” is unsuccessful in the opinion of the engineer. If the “Cable Method” can be declared unsuccessful if and only if the engineer declares that it is unsuccessful then which the “Boring Method” should be attempted next in the replacement of the water service line. All costs associated with attempting to remove the existing water service line shall be included in this pay item. Payment will be based on “EACH” location where the use of the “Cable Method” is unsuccessfully attempted.

Payment for **Failed Attempt, Boring Method**: This pay item is for when the attempt to replace the water service line using the “Boring Method” is unsuccessful in the opinion of the engineer. If the “Boring Method” can be declared unsuccessful if and only if the engineer declares that it is unsuccessful then which the water service line will be installed in an open trench. All costs associated with attempting to remove the existing water service line shall be included in this pay item. Payment will be based on “EACH” location where the use of the “Boring Method” is unsuccessfully attempted.

Payment for **Water Main Tap**: This shall include all labor, materials, and equipment necessary to install a new water main tap and corporation. Payment will be based on “EACH”.

SPECIAL PROVISION
FOR
WATER METER PIT, REM

City of Owosso/GC

1 of 1

April, 2020

a. Description. Work consists of removing existing meter pits as required in the Contract Documents and as directed by the City of Owosso and Engineer. This work includes furnishing all labor, equipment, and material required for the excavation, removal, salvaging, disposal of removed materials, backfilling, and all related work necessary to complete the water meter pit removal.

b. Materials. The City of Owosso shall have right of refusal on all meter pit materials. All other material shall be properly disposed of off site by the Contractor.

c. Construction. The City of Owosso will remove the meter and meter transmission unit (MTU) from the existing meter pit and reinstall in the new meter pit. The Contractor shall not remove or handle the existing water meter or the meter transmission unit.

Remove all portions of the existing meter pit only after the new meter pit is installed and in service. The City of Owosso will inspect and advise on the materials desired to be salvaged during the removal of the existing meter and meter transmission unit. Salvaged materials will be picked up on site by the City of Owosso.

d. Measurement and Payment. The completed work, as described, will be measured and paid for at the contract unit price using the following contract pay item:

Pay Item	Pay Unit
Water Meter Pit, Rem	Each

Water Meter Pit, Rem will be measured in place by the unit Each and will be paid for at the contract unit price per Each, which price shall be payment in full for all labor, materials, and equipment necessary to complete this work. The unit price shall include coordinating meter removal and installation with City of Owosso; excavation; removal and disposal; providing, placing, and compacting backfill; and salvaging existing materials as directed.

Installation of new or replacement meter pit shall be paid for as Supply & Install Meter Pit, Complete.

SPECIAL PROVISION
FOR
SUPPLY & INSTALL METER PIT, COMPLETE

City of Owosso/GC

1 of 2

April, 2020

a. Description. Work consists of the installation of a new water meter pit or replacement of an existing water meter pit, as required in the Contract Documents and as directed by the City of Owosso and Engineer. This work includes furnishing all labor and equipment required for the excavation, installation, backfilling, and all related work necessary to complete the water meter pit installation.

b. Materials. Water meter pits are to be installed in lawn areas that are not subject to vehicular traffic.

Water meter pit materials are identified on the Typical Meter Pit Detail on the following page. The City of Owosso will provide all new materials for the installation of the meter pits.

c. Construction. Construct meter pit in accordance with the Typical Meter Pit Detail. The City of Owosso will pull the existing meter from the meter pit to be removed and reinstall the meter in the new pit. The Contractor shall not handle or install the water meter or the meter transmission unit (MTU).

The City of Owosso will assist with the installation of the first couple of meter pits.

Existing meter pits may be eliminated with the meter being reinstalled inside the dwelling if determined feasible by the City of Owosso. All meter installs will be completed by the City.

d. Measurement and Payment. The completed work, as described, will be measured and paid for at the contract unit price using the following contract pay item:

Pay Item	Pay Unit
Supply & Install Meter Pit, Complete	Each

Supply & Install Meter Pit, Complete will be measured in place by the unit Each and will be paid for at the contract unit price per Each, which price shall be payment in full for all labor, incidental material, and equipment necessary to complete this work. The unit price shall include verifying location of existing water service; notification of temporary service disruption; coordinating meter install with City of Owosso; picking up new materials from City of Owosso; excavation; bedding, installing meter pit; providing, placing, and compacting backfill; disposal of excess material; and adjustment of meter pit to finished grade. Materials shall be provided by City of Owosso at no charge to Contractor.

Removal of existing meter pit shall be paid for as Water Meter Pit, Rem.

TYPICAL METER PIT DETAIL

NOT TO SCALE

1" COPPER: MAIN TO STOP 1" COOPER OR PEX: STOP TO HOUSE
(NO GALVANIZED ALLOWED)

DEQ
ALL PARTS MUST BE STAMPED
NL
FOR NO LEAD

- ① FORD STOP
B-41-343-Q-NL 3/4" FEMALE x 1" CTS COMP
71 SERIES

- ② FORD METER RISER
71-33-61-33-NL 3/4" FEMALE x 3/4" MALE
71 SERIES

- ③ FORD COUPLING
C84-34-Q-NL

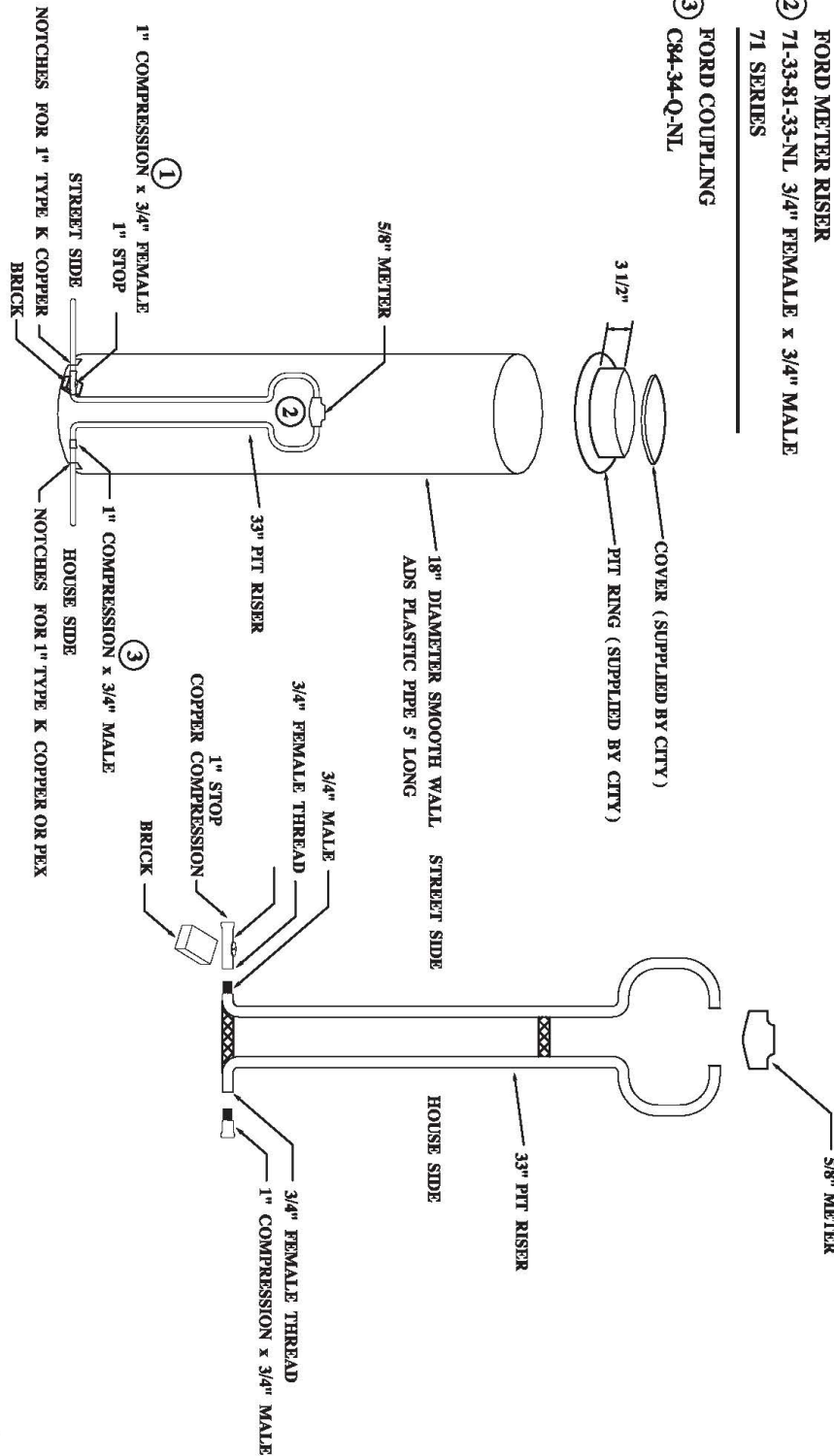

REVISED 1/2020

TYPICAL HORIZONTAL IN LINE METER DETAIL

NOT TO SCALE

(NO GALVANIZED ALLOWED)

1" METER INSTALL
DOES NOT NEED REDUCER

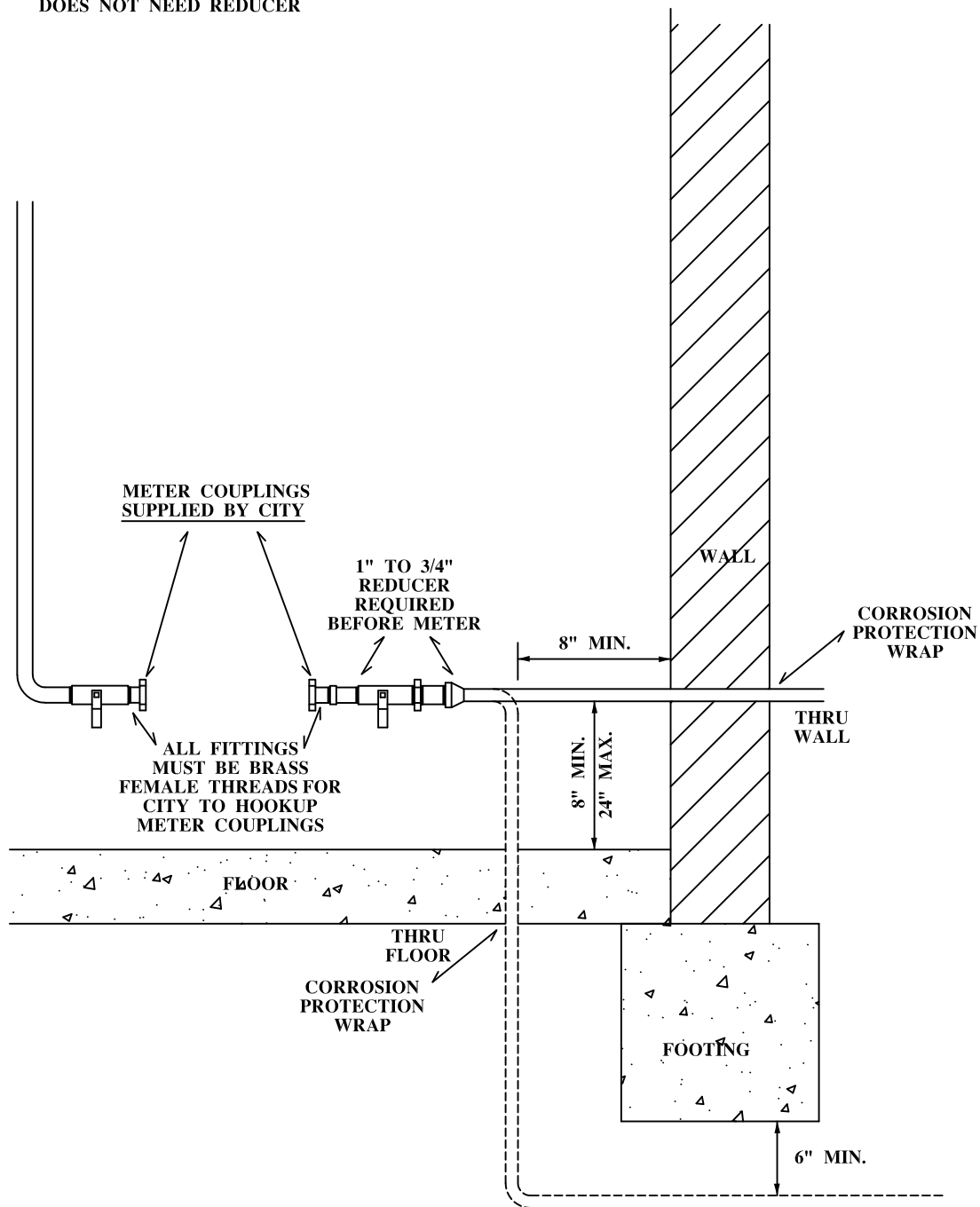

FIGURE 1a

RESIDENTIAL 1" WATER SERVICE FOR 5/8", 3/4", OR 1" METER

REVISED 1/2020

TYPICAL VERTICAL IN LINE METER DETAIL

NOT TO SCALE

(NO GALVANIZED ALLOWED)

1" METER INSTALL
DOES NOT NEED REDUCER

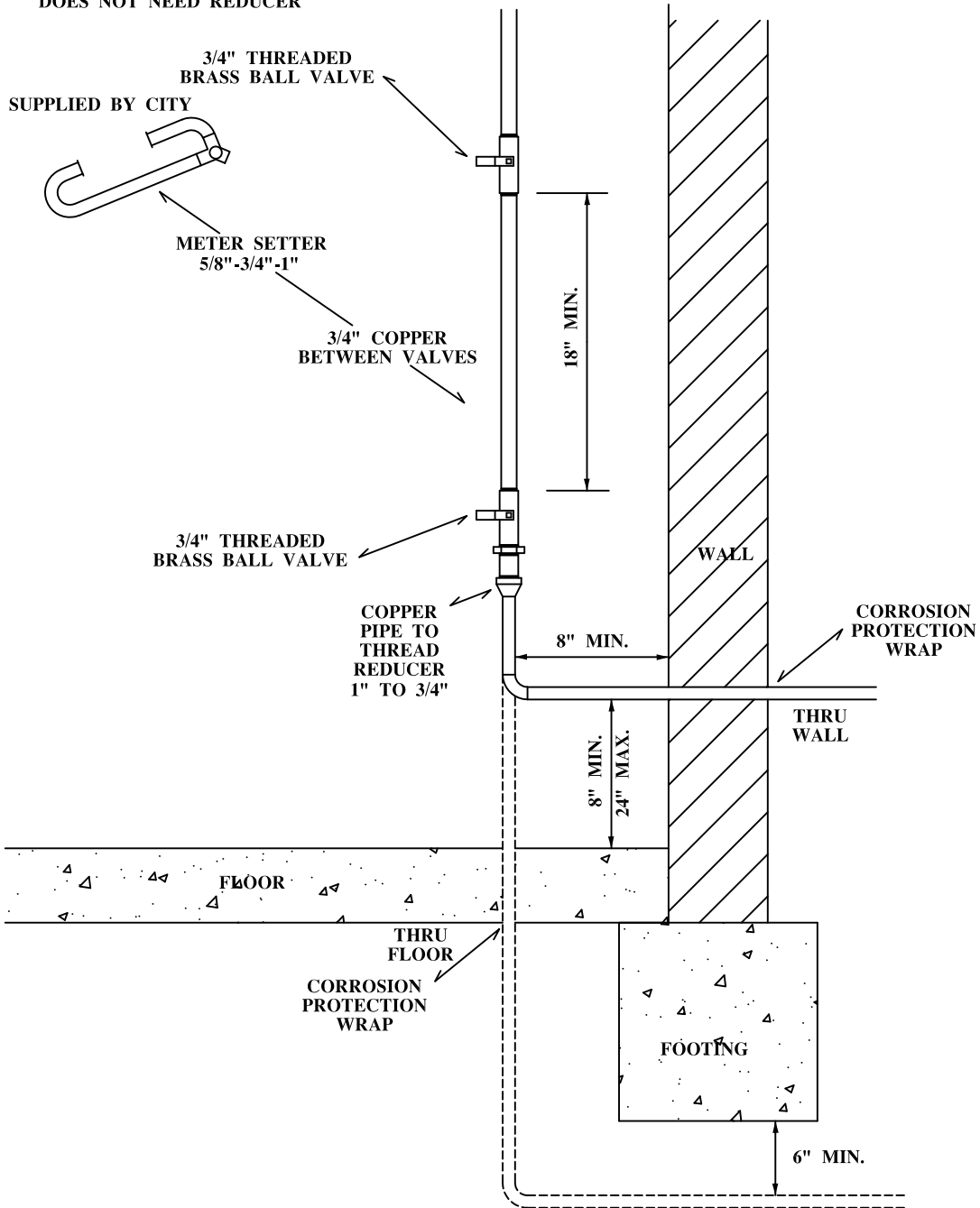
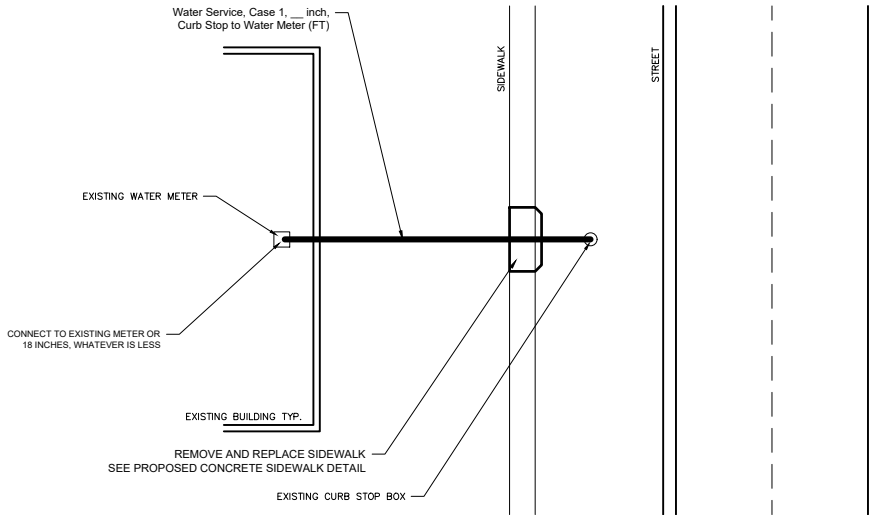

FIGURE 1b

RESIDENTIAL 1" WATER SERVICE FOR 5/8", 3/4", OR 1" METER

REVISED 1/2020

CASE #1 TYP. - CURB STOP TO WATER METER



NOTES:

- 1.) EXCAVATE AT EXISTING CURB STOP BOX A MINIMUM OF 2 FEET IN EACH DIRECTION. TEMPORARILY REMOVE CURB STOP BOX/VALVE.
- 2.) SAWCUT/REMOVE 10 FEET OF EXISTING SIDEWALK, PAID FOR AS Sidewalk, Rem. CONTRACTOR SHALL MAINTAIN THE AREA WITH MAINTENANCE GRAVEL UNTIL NEW CONCRETE CAN BE POURED. COST FOR MAINTENANCE GRAVEL SHALL BE INCIDENTAL TO THE PROJECT AND NOT PAID FOR SEPARATELY.
- 3.) THE CONTRACTOR SHALL ATTEMPT TRENCHLESS INSTALLATION OF NEW WATER SERVICE LINE (CABLE METHOD, THEN BORING METHOD) FIRST. IF THESE METHODS FAIL, THE SERVICE LEAD SHALL BE PLACED IN AN OPEN TRENCH.
- 4.) FAILED ATTEMPTS AT TRENCHLESS INSTALLATION (CABLE/BORED) SHALL BE PAID FOR AS Failed Attempt - Cable Method OR Failed Attempt - Boring Method.
- 5.) THE NEW WATER SERVICE LINE SHALL EXTEND TO THE EXISTING WATER METER OR 18 INCHES, WHATEVER IS LESS. SHUT OFF VALVES SHALL BE INSTALLED WHERE NEEDED. COST SHALL BE INCLUDED WITH THE WATER SERVICE PAT ITEM AND NOT PAID FOR SEPARATELY.
- 6.) ALL NON-PAVED DISTURBED AREAS SHALL BE RESTORED WITH TURF. COST SHALL BE INCLUDED IN THE WATER SERVICE LINE PAY ITEM AND NOT PAID FOR SEPARATELY.

CASE #1 SERVICE LEAD QUANTITIES (FOR INFORMATION ONLY)

Address	Existing Material Type	Copper Service Lead (FT)	Notes
516 Garfield	Galvanized	25	Replace meter pit
532 Garfield	Galvanized	5	
1428 Pearce	Galvanized	40	Replace meter pit
1434 Pearce	Galvanized	50	Replace meter pit
703 Glenwood	Galvanized	20	PEX entering building
822 Glenwood	Galvanized	25	Replace meter pit
903 S Park	Unknown	25	
TOTAL:		190	



CASE #2 TYP. - WATER MAIN TO CURB STOP

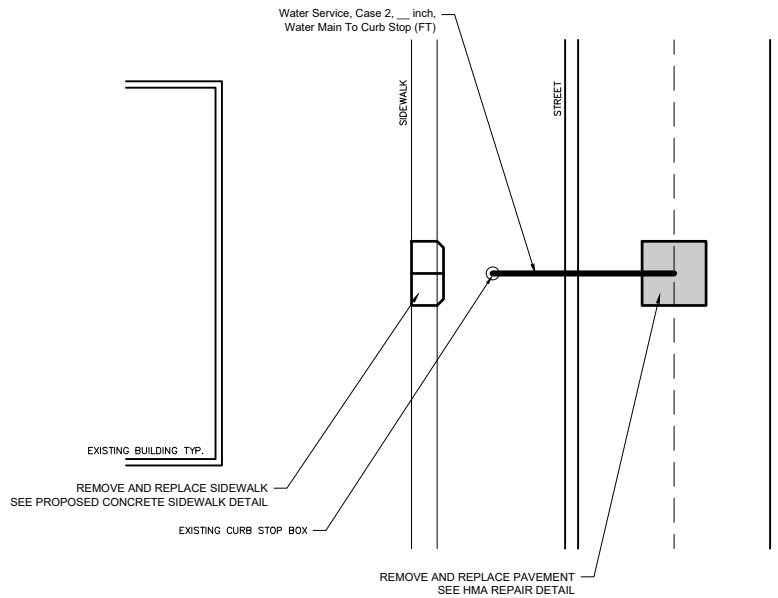

NOTES:

- 1.) EXCAVATE AT EXISTING CURB STOP BOX A MINIMUM OF 2 FEET IN EACH DIRECTION. TEMPORARILY REMOVE CURB STOP BOX/VALVE.
- 2.) SAWCUT/REMOVE 10 FEET OF EXISTING SIDEWALK, PAID FOR AS Sidewalk, Rem. CONTRACTOR SHALL MAINTAIN THE AREA WITH MAINTENANCE GRAVEL UNTIL NEW CONCRETE CAN BE POURED. COST FOR MAINTENANCE GRAVEL SHALL BE INCIDENTAL TO THE PROJECT AND NOT PAID FOR SEPARATELY.
- 3.) SAWCUT/REMOVE PAVEMENT OVER EXISTING WATERMAIN, PAID FOR AS HMA, Rem. CONTRACTOR SHALL MAINTAIN THE AREA WITH MAINTENANCE GRAVEL UNTIL NEW PAVEMENT CAN BE PLACED. COST FOR MAINTENANCE GRAVEL SHALL BE INCIDENTAL TO THE PROJECT AND NOT PAID FOR SEPARATELY. ADDITIONAL QUANTITY FOR CURB REMOVAL AND REPLACEMENT ARE INCLUDED TO BE USED AS DIRECTED BY THE ENGINEER.
- 4.) THE CONTRACTOR SHALL ATTEMPT TRENCHLESS INSTALLATION OF NEW WATER SERVICE LINE (CABLE METHOD, THEN BORING METHOD) FIRST. IF THESE METHODS FAIL, THE SERVICE LEAD SHALL BE PLACED IN AN OPEN TRENCH.
- 5.) FAILED ATTEMPTS AT TRENCHLESS INSTALLATION (CABLE/BORED) SHALL BE PAID FOR AS Failed Attempt - Cable Method OR Failed Attempt - Boring Method.
- 6.) ALL NON-PAVED DISTURBED AREAS SHALL BE RESTORED WITH TURF. COST SHALL BE INCLUDED IN THE WATER SERVICE LINE PAY ITEM AND NOT PAID FOR SEPARATELY.

CASE #2 SERVICE LEAD QUANTITIES (FOR INFORMATION ONLY)

Address	Existing Material Type	Copper Service Lead (FT)	Notes
522 Garfield	Lead	35	Replace meter pit
533 Garfield	Lead	10	
1301 Pearce	Lead	15	
1426 Pearce	Lead	45	Replace meter pit
1018 S Park	Lead	35	
533 Ament	Lead	45	
716 Corunna	Lead	45	
654 First	Lead	15	
415 W King	Lead	45	Replace meter pit
221 Osburn	Lead	15	
516/518 N Park	Lead	15	
318 W Oliver	Lead	10	
212 W Ridge	Lead	20	
TOTAL:		350	



CASE #3 TYP. - WATER MAIN TO WATER METER

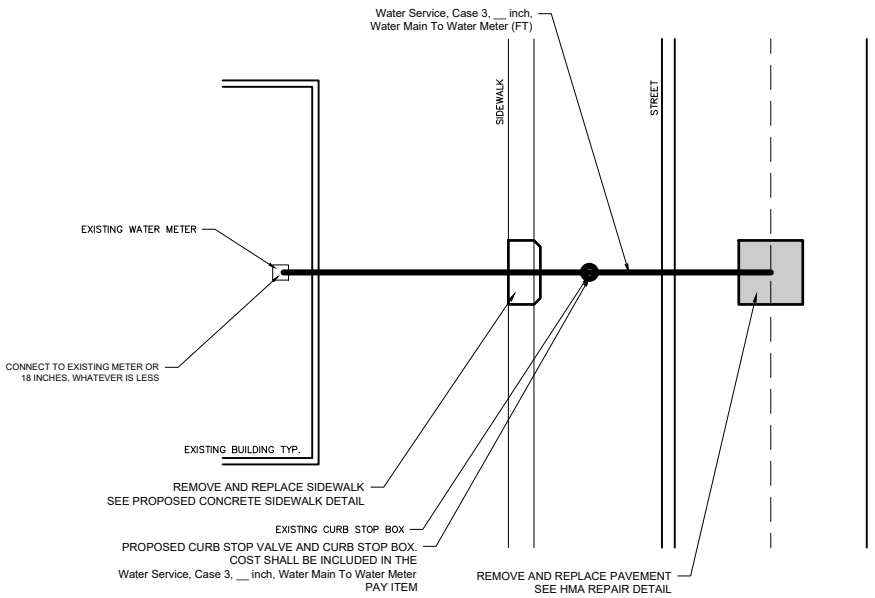

NOTES:

- 1.) EXCAVATE AT EXISTING CURB STOP BOX A MINIMUM OF 2 FEET IN EACH DIRECTION. TEMPORARILY REMOVE CURB STOP BOX/VALVE.
- 2.) SAWCUT/REMOVE 10 FEET OF EXISTING SIDEWALK, PAID FOR AS Sidewalk, Rem. CONTRACTOR SHALL MAINTAIN THE AREA WITH MAINTENANCE GRAVEL UNTIL NEW CONCRETE CAN BE POURED. COST FOR MAINTENANCE GRAVEL SHALL BE INCIDENTAL TO THE PROJECT AND NOT PAID FOR SEPARATELY.
- 3.) SAWCUT/REMOVE PAVEMENT OVER EXISTING WATERMAIN, PAID FOR AS HMA, Rem. CONTRACTOR SHALL MAINTAIN THE AREA WITH MAINTENANCE GRAVEL UNTIL NEW PAVEMENT CAN BE PLACED. COST FOR MAINTENANCE GRAVEL SHALL BE INCIDENTAL TO THE PROJECT AND NOT PAID FOR SEPARATELY. ADDITIONAL QUANTITY FOR CURB REMOVAL AND REPLACEMENT ARE INCLUDED TO BE USED AS DIRECTED BY THE ENGINEER.
- 4.) THE CONTRACTOR SHALL ATTEMPT TRENCHLESS INSTALLATION OF NEW WATER SERVICE LINE (CABLE METHOD, THEN BORING METHOD) FIRST. IF THESE METHODS FAIL, THE SERVICE LEAD SHALL BE PLACED IN AN OPEN TRENCH.
- 5.) FAILED ATTEMPTS AT TRENCHLESS INSTALLATION (CABLE/BORED) SHALL BE PAID FOR AS Failed Attempt - Cable Method OR Failed Attempt - Boring Method.
- 6.) THE NEW WATER SERVICE LINE SHALL EXTEND TO THE EXISTING WATER METER OR 18 INCHES, WHATEVER IS LESS. SHUT OFF VALVES SHALL BE INSTALLED WHERE NEEDED. COST SHALL BE INCLUDED WITH THE WATER SERVICE PAT ITEM AND NOT PAID FOR SEPARATELY.
- 7.) ALL NON-PAVED DISTURBED AREAS SHALL BE RESTORED WITH TURF. COST SHALL BE INCLUDED IN THE WATER SERVICE LINE PAY ITEM AND NOT PAID FOR SEPARATELY.

CASE #3 SERVICE LEAD QUANTITIES (FOR INFORMATION ONLY)

Address	Existing Material Type		Copper Service Lead (FT)	Notes
	City Side	Private Side		
519 Garfield	Lead	Galvanized	35	Replace meter pit
1412 Pearce	Lead	Galvanized	70	
1420 Pearce	Lead	Galvanized	70	
720 W South	Lead	Galvanized	55	
TOTAL:			230	



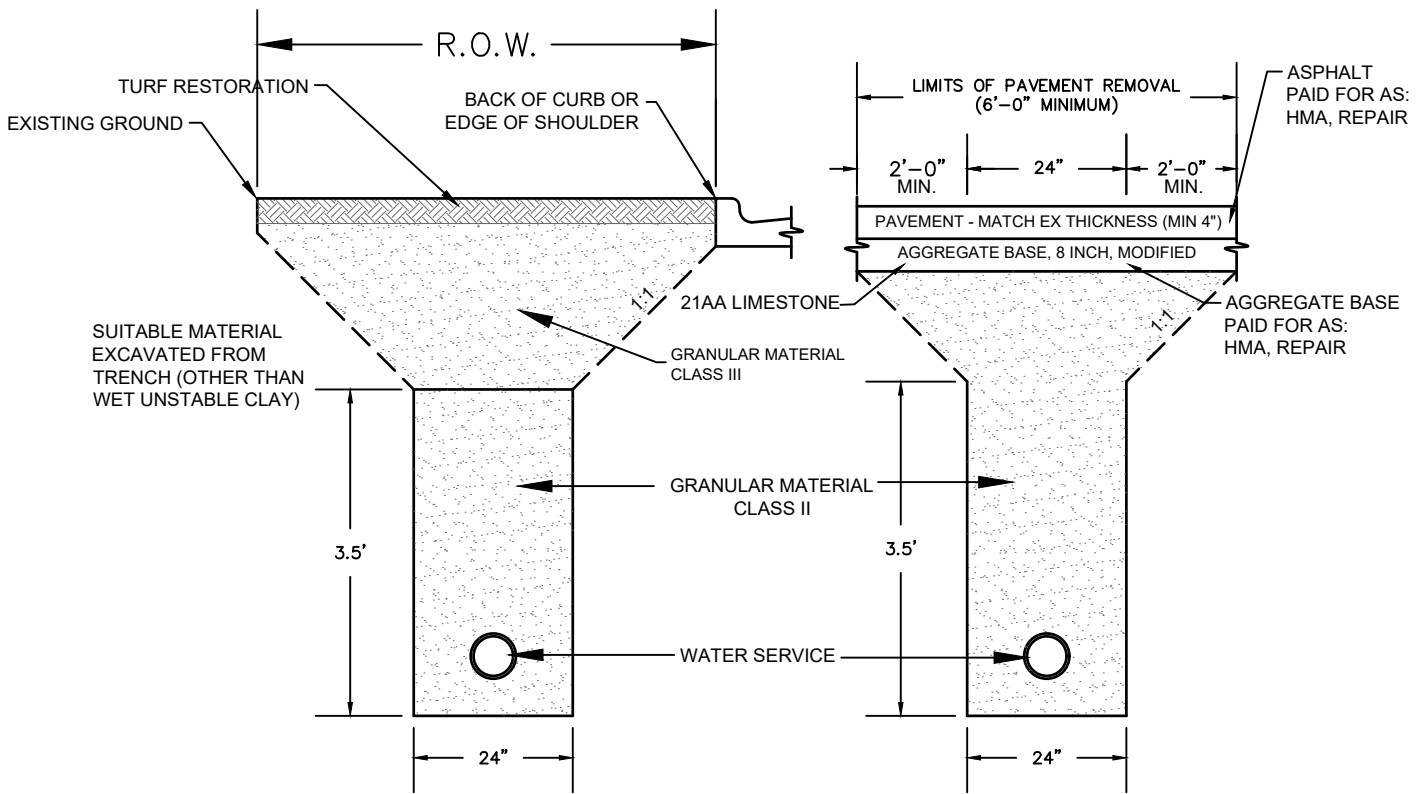

TRENCH BACKFILL DETAIL 'G'
 TYPICAL WATER SERVICE LINE
 UNDER ROADBED AND/OR WITHIN INFLUENCE OF
 ROADBED, DRIVEWAY, OR SIDEWALK, OR
 LOCATED WITHIN THE ROAD RIGHT-OF-WAY
 OR IN LAWN AREA

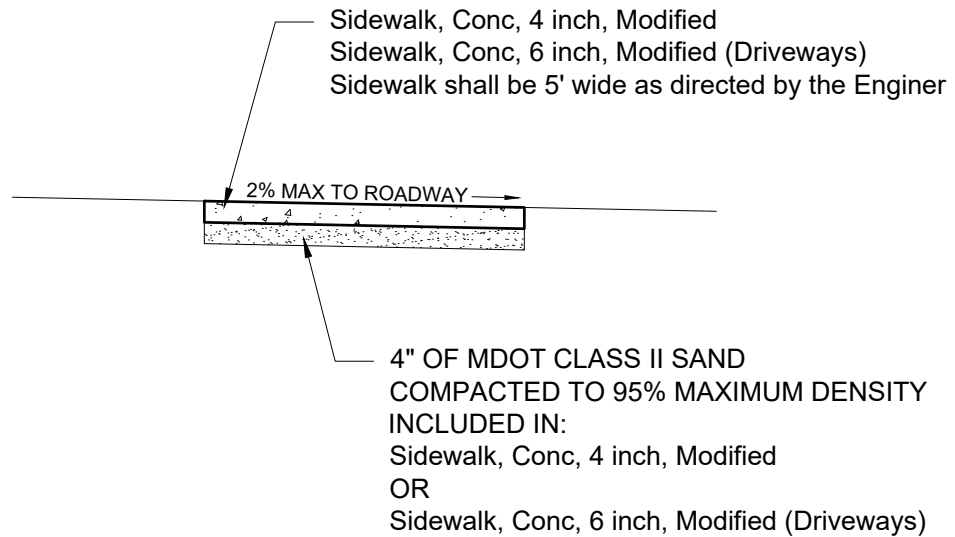

PROPOSED CONCRETE SIDEWALK DETAIL - NOT TO SCALE



City of Owosso

2021 Water Service Line Replacements

NE Quadrant

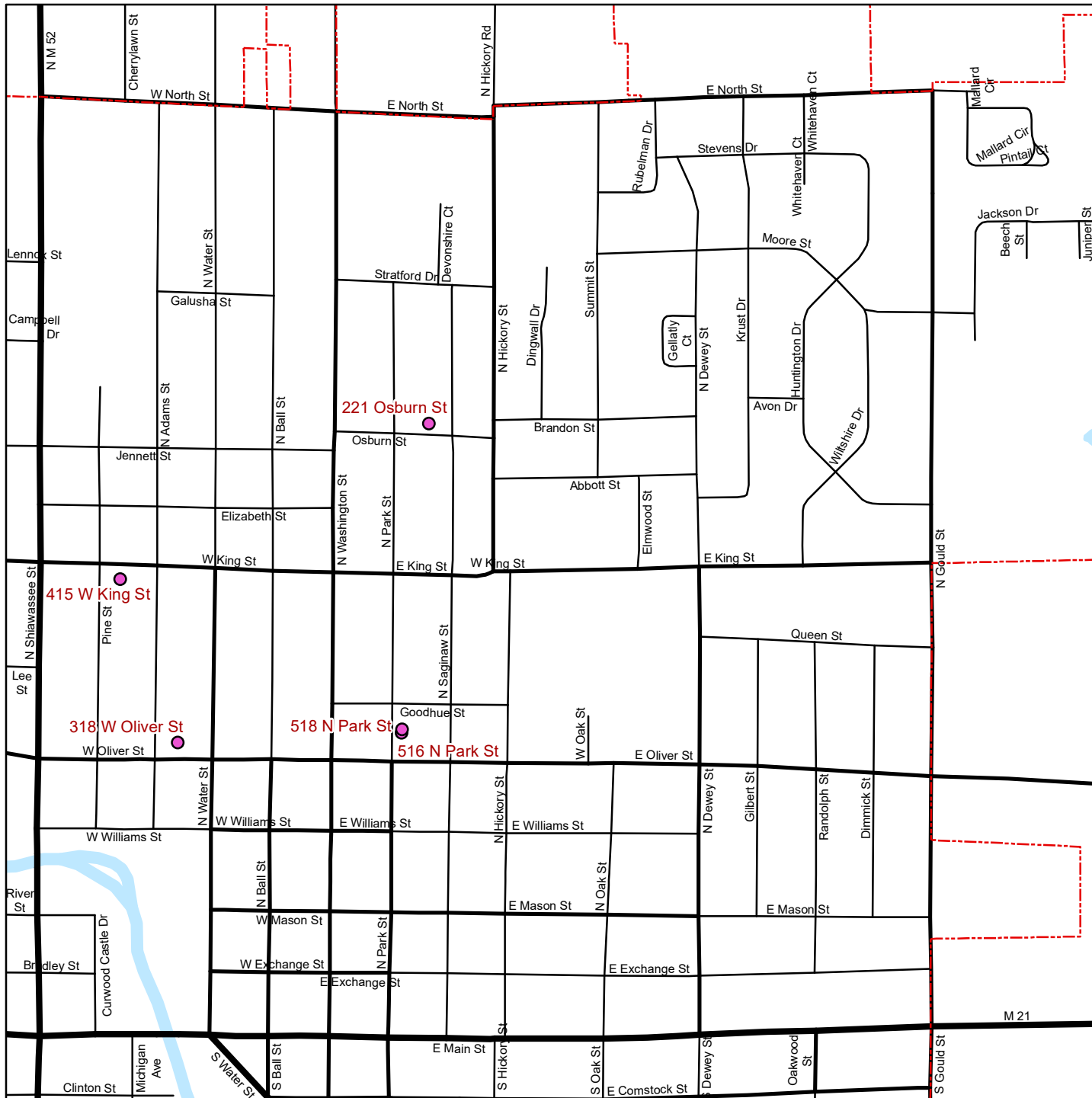

Replacement Locations

Case Type

- 1: Curb Stop to Water Meter
- 2: Water Main to Curb Stop
- 3: Water Main to Water Meter

Other Features

- City Limit
- Railroads
- Lakes and River

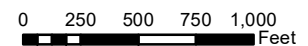

City of Owosso

2021 Water Service Line Replacements

NW Quadrant

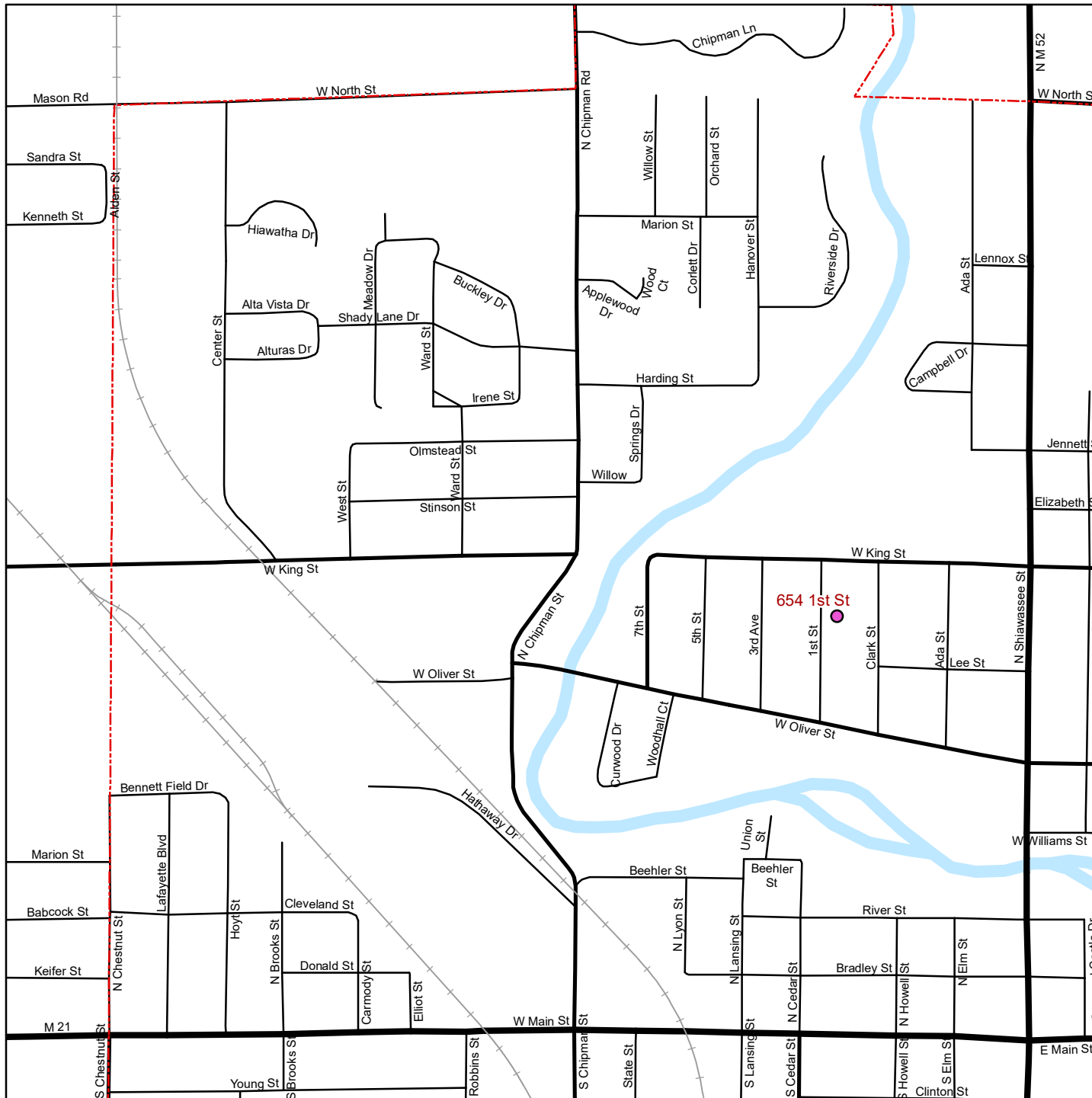

Replacement Locations

Case Type

- 1: Curb Stop to Water Meter
- 2: Water Main to Curb Stop
- 3: Water Main to Water Meter

Other Features

- - - City Limit
- Railroads
- Lakes and River

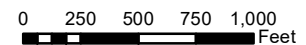

City of Owosso

2021 Water Service Line Replacements

SE Quadrant

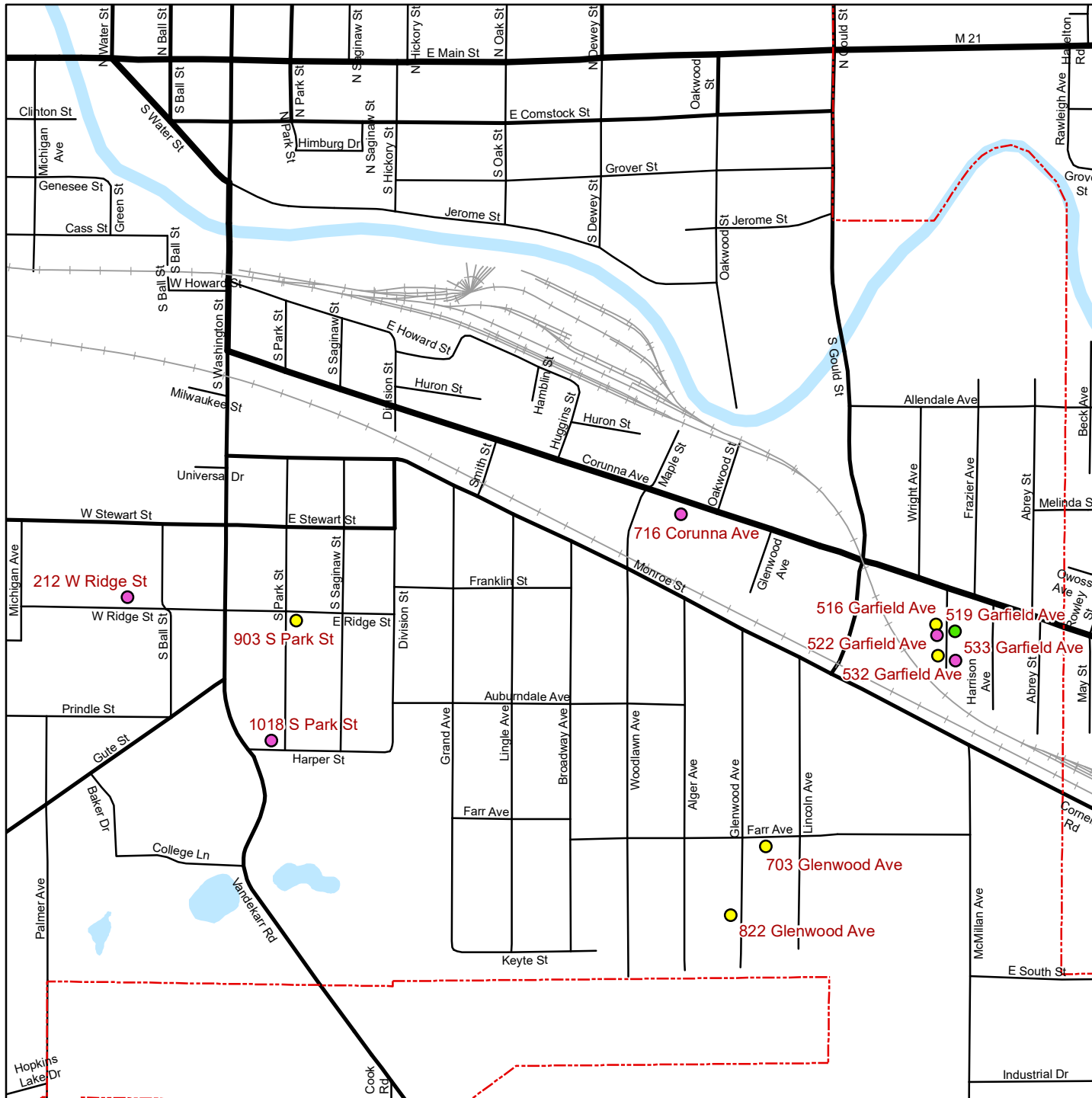

Replacement Locations

Case Type

- 1: Curb Stop to Water Meter
- 2: Water Main to Curb Stop
- 3: Water Main to Water Meter

Other Features

- City Limit
- Railroads
- Lakes and River

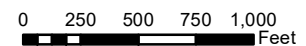

City of Owosso

2021 Water Service Line Replacements

SW Quadrant

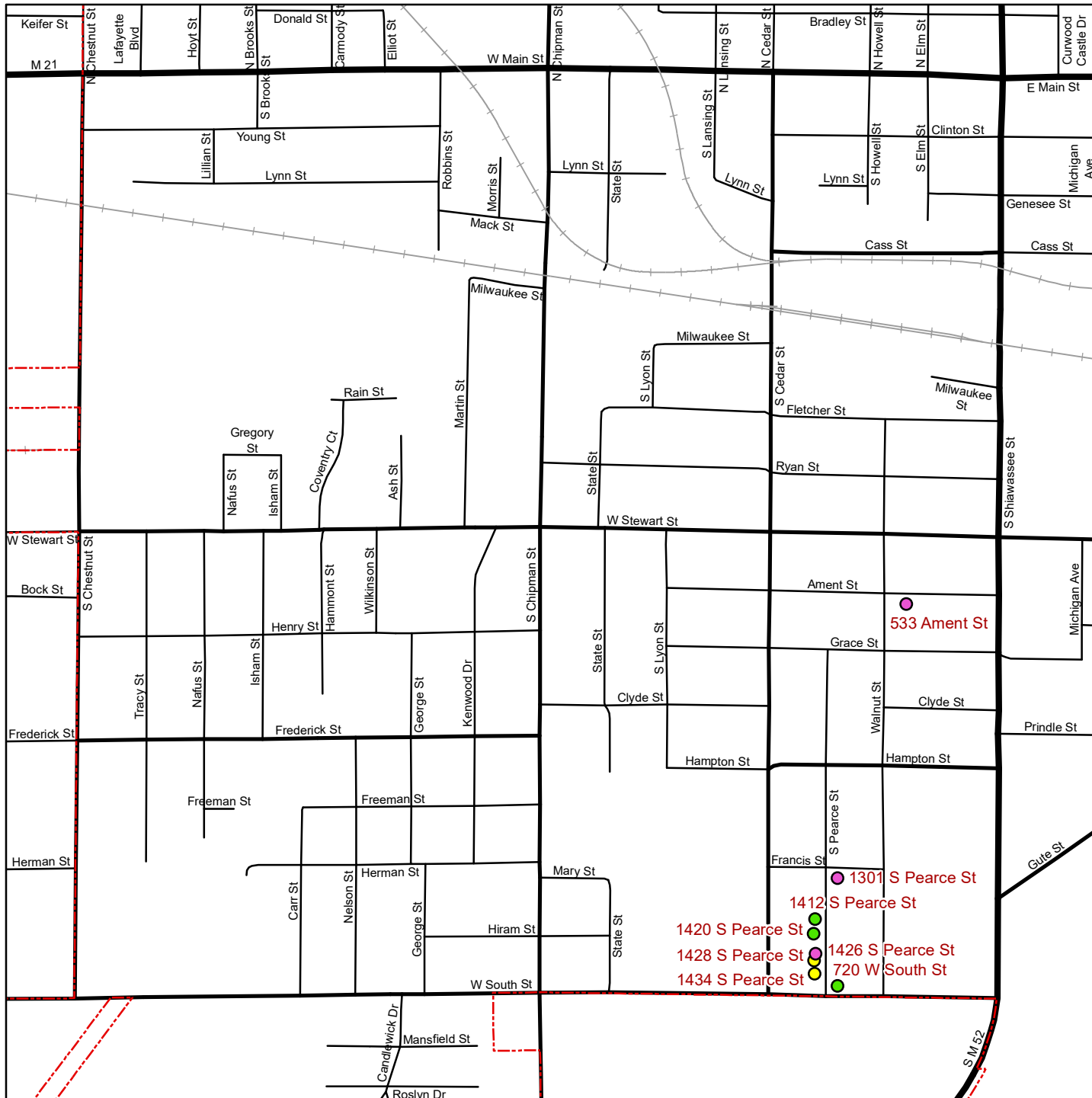

Replacement Locations

Case Type

- 1: Curb Stop to Water Meter
- 2: Water Main to Curb Stop
- 3: Water Main to Water Meter

Other Features

- - - City Limit
- +— Railroads
- Lakes and River

